

6Axx-A1C Six Bolt Composite Disc Replacement

Disc Replacement Instructions For Single-Flex A1C Composite Disc Couplings



TOOLS REQUIRED

- Calibrated torque wrench
- Hex socket for disc and clamp pack socket head cap screws (see Tables on page 2 for size and minimum length)
- Cleaning cloth
- Ratchet for sockets (optional)
- Loosen the clamp hub cap screws (see Table 2 on page 2) and remove coupling from shafts.
- Secure coupling, taking care not to mar surface.
- Remove disc pack socket screws (both sets) by inserting hex wrench in access holes (see Diagram on page 2).
- Remove disc pack.
- Place three disk pack socket head cap screws (see Table 1 on page 2) with head down into clearance holes of the hub.
- Check the hub counter bores and disc pack bushings for debris and wipe clean if necessary. Install disc pack onto the hub, positioning one set of disc pack bushings over the upside down socket head cap screws and the other set of bushings over the hub counter bores. Install the other three disc pack socket head cap screws into the hub's threaded holes and hand-tighten until disc pack does not move. Visually check to make sure the disc pack bushings have seated into the counter bores.
- Using a torque wrench and hex socket, tighten the three disc pack socket head cap screws to their proper tightening torque (see Table 1 on page 2).
- Place hub / disc pack onto second hub. Make sure to place the two clamp hubs in their proper orientation by lining up the clamp hub socket head cap screw centerline's as close as possible. Line up the socket cap screw heads with the clearance holes and the threads of the second set of socket head cap screws with the counter bores.
- Using a hex wrench, hand tighten second set of disc pack fasteners by using the wrench in the wrench access hole of the hub / disc assembly. Tighten one screw three to eight turns and move to the next screw. Repeat this process until the screws are tight against the disc pack. This process prevents the disc pack from binding on the screws. Visually check to make sure the disk pack have seated into the hub counter bores. Using a torque wrench and hex socket tighten the three disc pack socket head cap screws to their proper tightening torque (see Table 1 on page 2).
- Wipe down coupling and re-install.

⚠ Caution: Rotating equipment is potentially dangerous and should be properly guarded. It is the responsibility of the machine builder, user, or operator to follow all applicable safety codes and provide a suitable guard. Make sure the machine is "locked out" and cannot be accidentally started during installation or maintenance of coupling.

6Axx-A1C Six Bolt Composite Disc Replacement

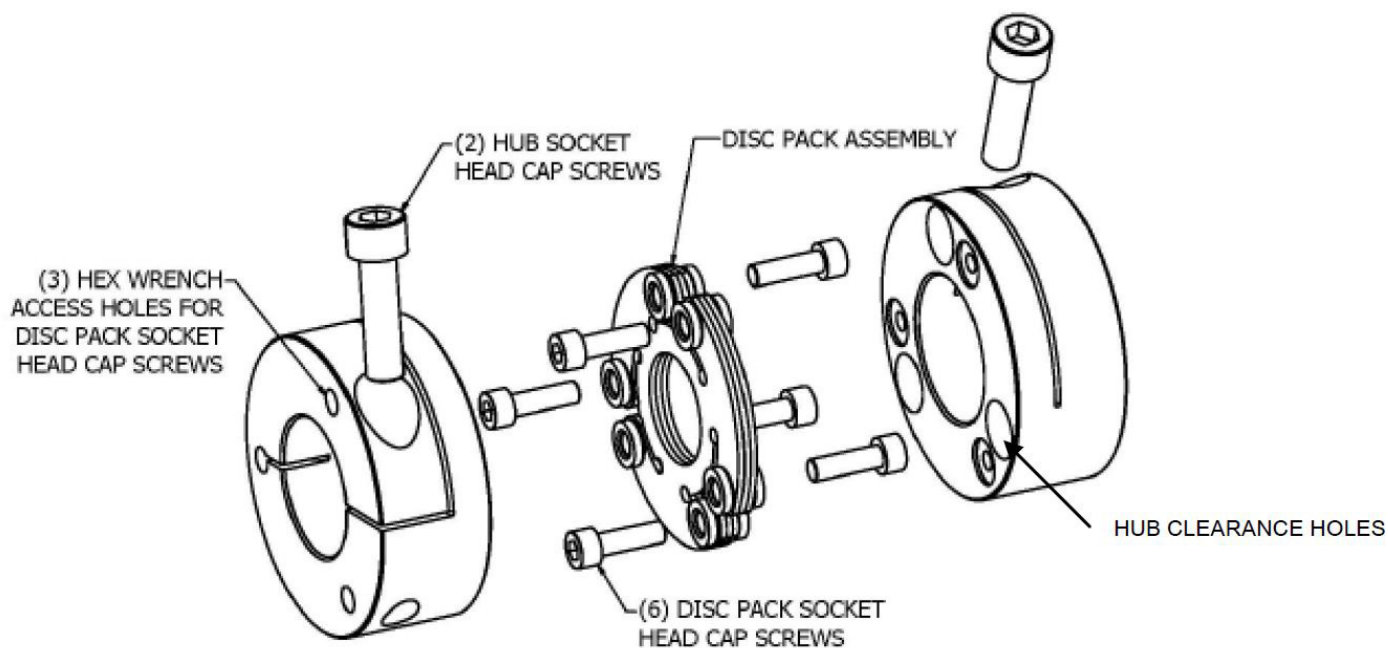

Table 1: Disc Pack Fastener Tightening Torque Table

Model	Qty	Part No	Description	Hex Wrench Size	Minimum Hex Wrench Length	Tightening Torque
6A18-A1C	6	A750300R	M3 x 12mm SHCS	2.5mm	0.87 in (22mm)	18 in-lb (214 Ncm)
6A22-A1C	6	A750515R	M5 X 16mm SHCS	4mm	1.02 in (26mm)	50 in-lb (564 Ncm)
6A26-A1C	6	A750515R	M5 X 16mm SHCS	4mm	1.18 in (30mm)	50 in-lb (564 Ncm)
6A30-A1C	6	A750622R	M6 x 20mm SHCS	5mm	1.30 in (33mm)	95 in-lb (10.7 Nm)
6A37-A1C	6	A750870	M8 x 30mm SHCS	6mm	1.81 in (46mm)	230 in-lb (26 Nm)
6A45-A1C	6	A751035	M10 x 35mm SHCS	8mm	2.36 in (60mm)	38 ft-lb (51 Nm)

Table 2: Clamp Hub Fastener Table

Model	Qty	Part No	Description	Hex Wrench Size
6A18-A1C	2	A750622R	M6 x 20mm SHCS	5mm
6A22-A1C	2	A450625	M6 x 25mm SHCS	5mm
6A26-A1C	2	A750870	M8 x 30mm SHCS	6mm
6A30-A1C	2	A751035	M10 x 35mm SHCS	8mm
6A37-A1C	2	A979113	M12 x 40mm SHCS	10mm
6A45-A1C	2	A751645	M16 x 45mm SHCS	14mm

Table 3: Replacement Disc Pack

Model	Part Number
6A18-A1C	A018002
6A22-A1C	A022000
6A26-A1C	A026000
6A30-A1C	A030000
6A37-A1C	A037000
6A45-A1C	A045000

