

## Control-Flex Single Disc Clamp Hub Coupling

C008P, C011P, C016P, C023P, C031P

### Installation Instructions For Control-Flex Single Disc Clamp Couplings

#### TOOLS REQUIRED

- Calibrated torque wrench
  - Hex socket set
  - Shaft alignment tools
  - Cleaning cloth
  - Caliper
- These instructions are for standard series Control-Flex Couplings with normal running conditions. Special couplings may have different instructions or drawings.
  - When initially mounting the coupling, the misalignment may be one and one half times the maximum permissible misalignment shown in the catalog. Inspect hub bores, shafts, and keyways making sure there are no burrs. Clean hub bores and shafts. Standard Control-Flex Coupling hubs are supplied with slight clearance fit (see catalog).

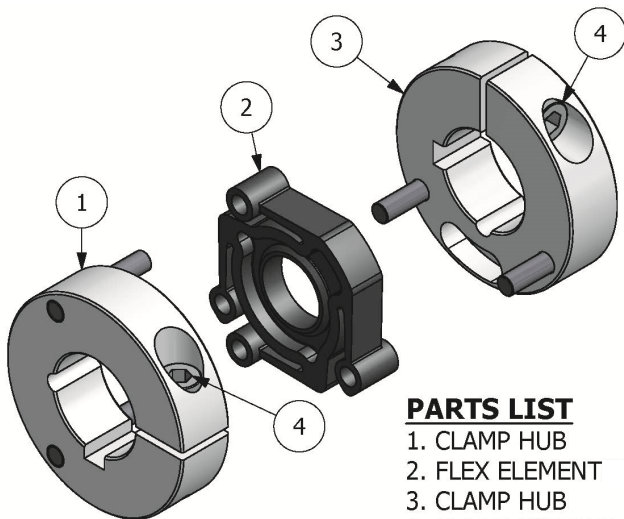

#### PARTS LIST

1. CLAMP HUB
2. FLEX ELEMENT
3. CLAMP HUB
4. CLAMP SCREWS

**Note:** If coupling was disassembled, reassemble coupling with raised bosses of the flex element facing the hubs. Main body of the flex element should not be in contact with the hub.

- Install the coupling onto the shafts. It is recommended that the ends of both shafts be flush with the end of each hub. If the shaft extends past the hub face verify there is enough clearance between shaft and flex disc that the shaft will not contact the flex disc during operation. Tighten one clamp hub socket head cap screw to lock the hub onto the shaft. See the table on page 2 for the proper tightening torque.
- Adjust hub separation to dimension “C” specified in the table and diagram on page 2. Tighten second hub to the shaft. See the table on page 2 for the proper tightening torque.
- Align the shafts within the limits for parallel and angular misalignment specified in table on page 2. For best alignment results, use a laser alignment tool or dial indicator. If not available, a straight edge and feeler gauges can be used.

**Note:** Aligning the shafts as closely as possible at the time of initial installation will reduce noise and allow the coupling extra capacity for misalignments and loads which will occur during operation over the life of the connected equipment. Installing and operating coupling at higher degrees of misalignment is possible (see catalog ratings), but will generally reduce the life of the flex disc.

**Note:** Coupling and shaft alignment should be checked periodically due to foundation settling, equipment shifting, etc. Alignment should be re-checked after the first several hours of operation.

**⚠ Caution: Rotating equipment is potentially dangerous and should be properly guarded. It is the responsibility of the machine builder, user, or operator to follow all applicable safety codes and provide a suitable guard. Make sure the machine is “locked out” and cannot be accidentally started during installation or maintenance of coupling.**

## Control-Flex Single Disc Clamp Hub Coupling

C008P, C011P, C016P, C023P, C031P

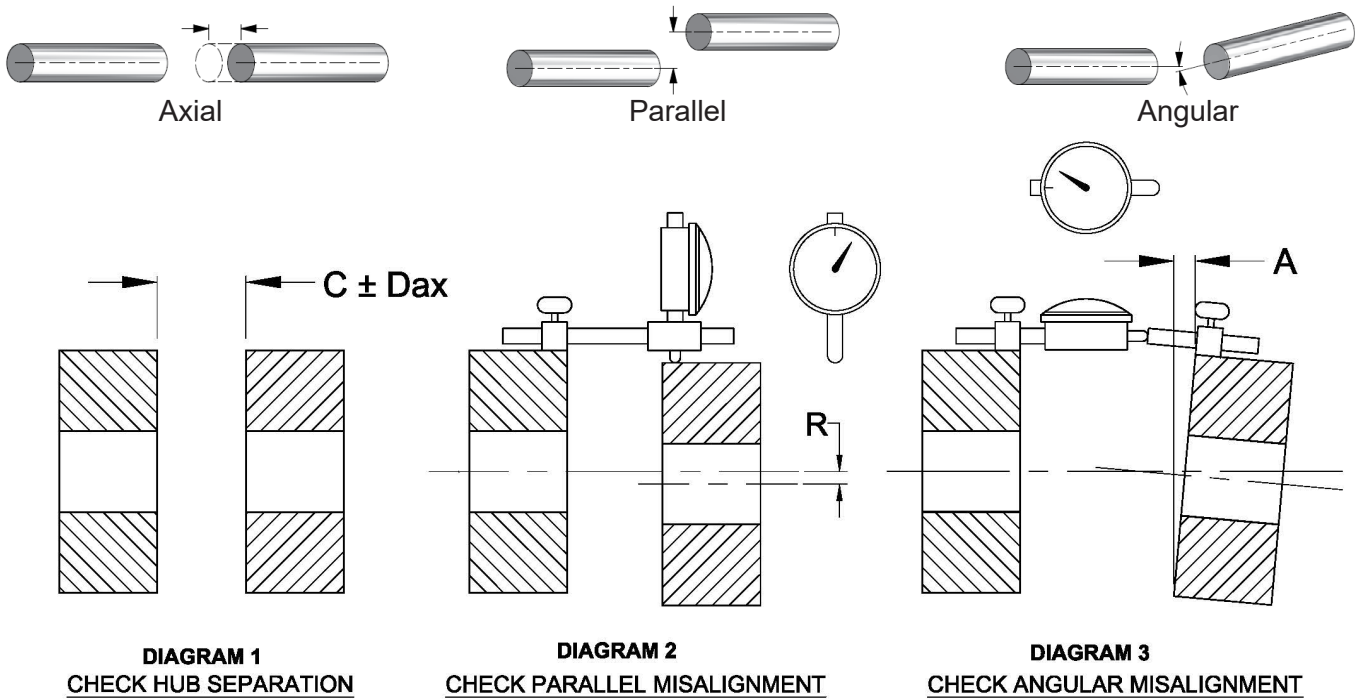

**Table 1: Alignment and Assembly Specifications for Control-Flex Single Disc Couplings.**

Model	Axial Separation and Misalignment		Parallel Misalignment	Angular Misalignment		Hub Clamp Screw Specifications	
	C	$D_{AX}$	R	A	Angle	Wrench Size	In-lb (Nm)
	Inch (mm)	Inch (mm)	Inch (mm)	Inch (mm)			
C008P	0.187 (4.75)	0.0016 (0.042)	0.0022 (0.055)	0.0032 (0.083)	0.25°	5/64 inch	3.5 (0.4)
C011P	0.250 (6.35)	0.0023 (0.059)	0.0032 (0.080)	0.0043 (0.011)	0.25°	2.5mm	11.5 (1.3)
C016P	0.375 (9.53)	0.0035 (0.089)	0.005 (0.13)	0.006 (0.15)	0.25°	3mm	27 (3)
C023P	0.562 (14.27)	0.005 (0.13)	0.007 (0.18)	0.010 (0.25)	0.25°	5mm	70 (8)
C031P	0.750 (19.05)	0.007 (0.18)	0.009 (0.23)	0.013 (0.33)	0.25°	6mm	212 (24)

**Note:** The above misalignment specifications are recommended values for installation. They allow for extra capacity from operation over time. Refer to the catalog for maximum allowable misalignment specifications.

