

**ZERO-MAX**

**Keyless Connections**

**ETP®**



# DISCOVER THE MANY WAYS KEYLESS CONNECTIONS FROM ZERO-MAX SAVE VALUABLE TIME AND RESOURCES IN PRODUCTION PROCESSES.

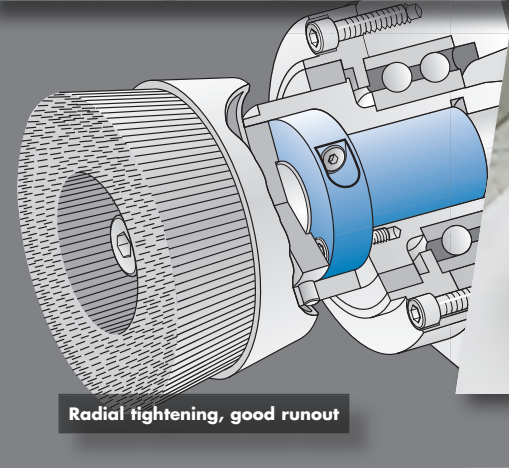
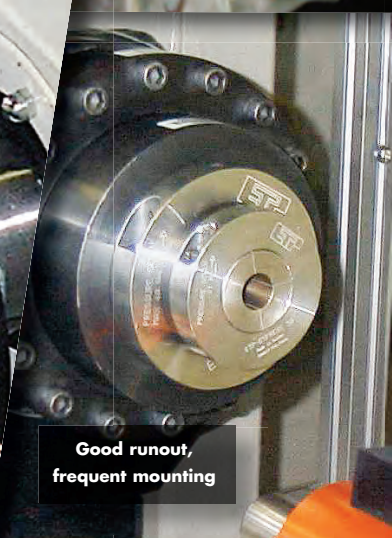
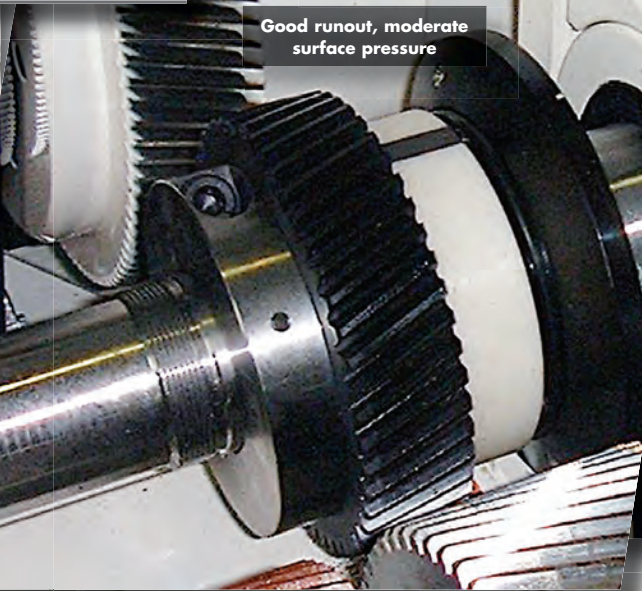
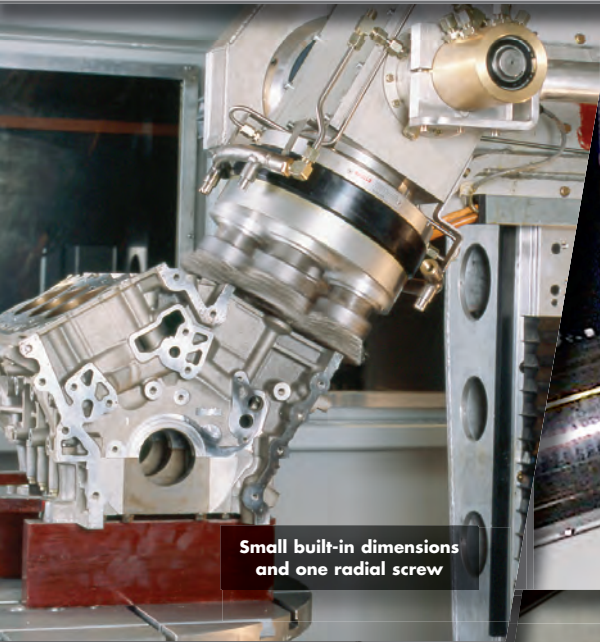



Excellent runout, very low TIR

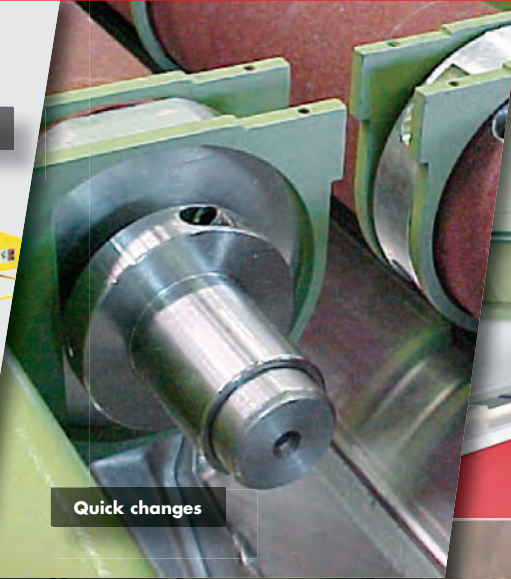

Quick changes



Easy to position and adjust with one screw

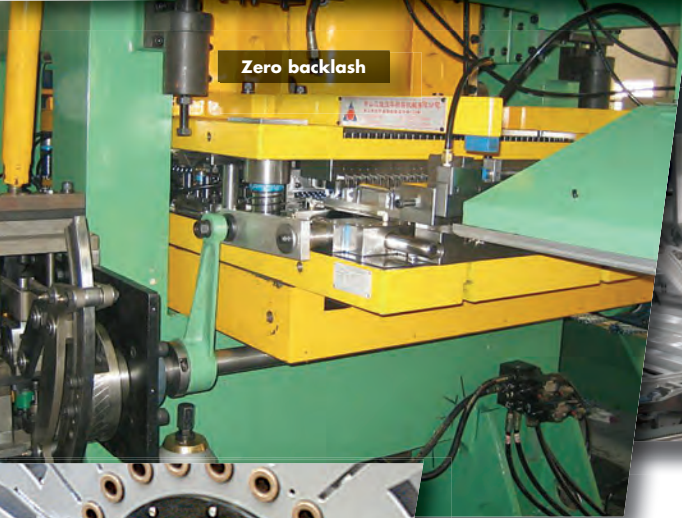

Zero backlash



Precise and accurate positioning, adjustment

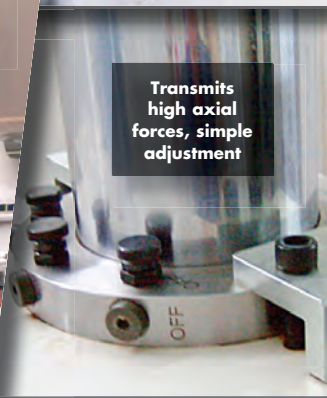

Transmits high axial forces, simple adjustment



Good runout, radial accessibility

## REASONS TO USE ETP KEYLESS CONNECTIONS

Zero-Max's ETP\* keyless connections are the perfect locking devices for shaft-to-hub connections. ETP keyless connections are ideal for positioning and locking shaft components in a system, and provide the best solution where keyways can weaken or cause excess wear to the shaft.

ETP keyless connections also address applications for synchronizing moving parts. They enable precise mounting of shaft components where frequent readjustments are required, in systems where balance and runout are inherent problems, and where common fastening, adjusting, and holding of shaft components are required.

We offer keyless locking devices that are designed to solve specific application requirements, such as high transmittable torque. Our ETP-CLASSIC and ETP-EXPRESS keyless connections are available in stainless steel for corrosion protection and to handle frequent washdowns.

- Mounting or dismantling in less than 10 seconds
- Shorten downtime for field servicing
- Fewer screws than alternative products
- Fast changeovers
- Zero backlash and superior concentricity
- Good corrosion resistance

See more keyless connection examples at [www.zero-max.com](http://www.zero-max.com)



## FEATURES

- High radial load capacity.
- Mounting and dismantling is fast.
- Precision adjustment of the hub can be made during mounting.
- Low tightening torque and small number of screws makes mounting easy and quick.
- Excellent concentricity even after many mountings.
- Hexhead screws can also be used.
- Handles temperature range -22°F to +185°F.

## Performance Information

Model	Transmittable			Polar moment of inertia lb ft² x10 <sup>-3</sup>	Weight lb	Hub Bore Tolerance			Shaft Tolerance				
	T lb ft	FA lbf	FR lbf			Upper Limit mm	Lower Limit mm	Grade	Upper Limit mm	Lower Limit mm	Grade		
ETP-15	41	1,641	562	0.45	0.22	23.018	-	23.000	H7	15.000	-	14.982	h7
ETP-19	74	2,383	1,304	1.07	0.37	28.021	-	28.000	H7	19.020	-	18.967	k6-h8*
ETP-3/4	65	2,091	1,304	1.07	0.37	28.021	-	28.000	H7	19.070	-	19.017	k6-h8*
ETP-20	92	2,810	1,484	1.02	0.35	28.021	-	28.000	H7	20.020	-	19.967	k6-h8*
ETP-22	100	2,765	1,843	1.50	0.44	32.025	-	32.000	H7	22.020	-	21.967	k6-h8*
ETP-7/8	100	2,720	1,843	1.26	0.44	32.025	-	32.000	H7	22.250	-	22.197	k6-h8*
ETP-15/16	129	3,305	2,203	1.57	0.44	34.025	-	34.000	H7	23.830	-	23.777	k6-h8*
ETP-24	148	3,754	2,203	1.57	0.44	34.025	-	34.000	H7	24.020	-	23.967	k6-h8*
ETP-25	184	4,496	2,383	1.59	0.44	34.025	-	34.000	H7	25.020	-	24.967	k6-h8*
ETP-1	144	3,642	2,473	1.59	0.48	35.025	-	35.000	H7	25.420	-	25.367	k6-h8*
ETP-28	221	4,811	2,945	2.66	0.60	39.025	-	39.000	H7	28.020	-	27.967	k6-h8*
ETP-1-1/8	207	4,384	2,945	2.66	0.57	39.025	-	39.000	H7	28.600	-	28.547	k6-h8*
ETP-30	310	6,294	3,305	3.16	0.66	41.025	-	41.000	H7	30.020	-	29.967	k6-h8*
ETP-1-3/16	251	5,058	3,305	3.16	0.64	41.025	-	41.000	H7	30.180	-	30.121	k6-h8*
ETP-1-1/4	302	5,867	3,664	4.27	0.79	43.025	-	43.000	H7	31.770	-	31.711	k6-h8*
ETP-32	310	5,912	3,664	4.27	0.77	43.025	-	43.000	H7	32.020	-	31.961	k6-h8*
ETP-1-3/8	398	6,991	4,046	5.46	0.90	47.025	-	47.000	H7	34.950	-	34.891	k6-h8*
ETP-35	479	8,340	4,226	5.46	0.90	47.025	-	47.000	H7	35.020	-	34.961	k6-h8*
ETP-1-7/16	428	7,149	4,496	6.57	0.99	50.025	-	50.000	H7	36.530	-	36.471	k6-h8*
ETP-38	553	8,880	4,766	6.57	0.97	50.025	-	50.000	H7	38.020	-	37.961	k6-h8*
ETP-1-1/2	516	8,250	4,833	9.68	1.15	52.030	-	52.000	H7	38.120	-	38.061	k6-h8*
ETP-40	693	10,566	5,125	9.68	1.26	53.030	-	53.000	H7	40.020	-	39.961	k6-h8*
ETP-1-5/8	627	9,262	5,283	9.82	1.28	55.030	-	55.000	H7	41.300	-	41.241	k6-h8*
ETP-42	693	10,071	5,485	9.82	1.23	55.030	-	55.000	H7	42.020	-	41.961	k6-h8*
ETP-1-3/4	870	11,914	5,845	15.09	1.65	59.030	-	59.000	H7	44.470	-	44.411	k6-h8*
ETP-45	951	12,881	6,047	15.09	1.68	59.030	-	59.000	H7	45.020	-	44.961	k6-h8*
ETP-48	1,158	14,702	6,587	18.06	1.76	62.030	-	62.000	H7	48.020	-	47.961	k6-h8*
ETP-1-15/16	1,069	13,241	6,744	22.38	2.09	65.030	-	65.000	H7	49.230	-	49.171	k6-h8*
ETP-50	1,401	17,085	6,946	22.38	2.01	65.030	-	65.000	H7	50.020	-	49.961	k6-h8*
ETP-2	1,195	14,455	7,081	30.87	2.38	68.030	-	68.000	H7	50.821	-	50.754	k6-h8*
ETP-55	1,844	20,434	7,868	30.87	2.40	71.030	-	71.000	H7	55.021	-	54.954	k6-h8*
ETP-60	2,508	25,402	8,790	46.49	3.09	77.030	-	77.000	H7	60.021	-	59.954	k6-h8*
ETP-2-1/2	2,286	21,940	9,329	65.97	3.99	84.035	-	84.000	H7	63.521	-	63.454	k6-h8*
ETP-65	2,581	24,278	9,689	65.97	3.79	84.035	-	84.000	H7	65.021	-	64.954	k6-h8*
ETP-70	3,835	33,495	10,611	95.75	4.61	90.035	-	90.000	H7	70.021	-	69.954	k6-h8*
ETP-2-15/16	3,909	34,394	11,352	130.52	5.69	95.035	-	95.000	H7	74.631	-	74.564	k6-h8*
ETP-75	4,646	37,766	11,532	130.52	5.53	95.035	-	95.000	H7	75.021	-	74.954	k6-h8*
ETP-3	3,909	31,270	11,802	225.44	5.73	98.035	-	98.000	H7	76.221	-	76.154	k6-h8*
ETP-80	6,490	49,456	12,364	192.22	5.91	100.035	-	100.000	H7	80.021	-	79.954	k6-h8*
ETP-85	6,490	46,534	13,038	225.44	6.81	106.035	-	106.000	H7	85.025	-	84.946	k6-h8*
ETP-90	8,113	54,851	13,488	289.51	7.76	112.035	-	112.000	H7	90.025	-	89.946	k6-h8*
ETP-95	9,440	60,471	13,825	405.79	9.83	120.035	-	120.000	H7	95.025	-	94.946	k6-h8*
ETP-100	11,431	69,688	13,938	473.42	10.73	125.040	-	125.000	H7	100.025	-	99.946	k6-h8*
ETP-4	9,219	59,347	13,938	473.42	11.55	130.040	-	130.000	H7	101.630	-	101.546	k6-h8*

T = Transmittable torque when axial force is 0. FA = Transmittable axial force when torque is 0. FR = Maximum radial force during continuous operation.  
 Maximum allowed bending torque = 15% of transmittable torque T. \* The tolerance grade k6-h8 is a range between the upper limit of the ISO grade k6 and the lower limit of the ISO grade h8.  
 Note: if the shaft is machined to a strict k6 tolerance range the transmittable torque will increase by 20%.

## DESIGN

ETP-Classic consists of a double-walled hardened steel sleeve filled with a specially designed pressure medium, sealing ring, piston, pressure flange and clamping screws.

## OPERATION

When tightening the actuation screws, the sleeve expands uniformly against the hub and shaft and creates a rigid joint. When loosening the actuation screws the sleeve returns to its original measurements and can easily be dismantled.

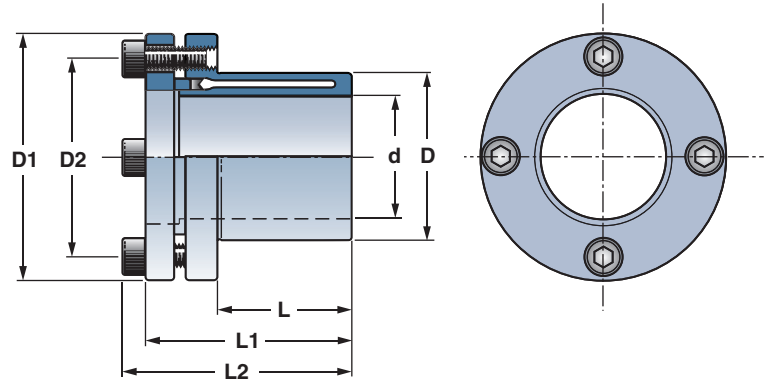

## Dimensional Information

Model	Dimensions							Screws		
	d mm	D mm	D1 mm	D2 mm	L mm	L1* mm	L2* mm	No.	Dim	Tt lb ft
ETP-15	15	23	38	28.5	17	30	35	3	M5	4.4
ETP-19	19	28	45	35.0	21	37	42	3	M5	5.9
ETP-3/4	19.05	28	45	35.0	21	35	40	3	M5	5.9
ETP-20	20	28	45	35.0	22	37	42	3	M5	5.9
ETP-22	22	32	49	40.0	22	37	42	4	M5	5.9
ETP-7/8	22.23	32	49	40.0	22	37	42	4	M5	5.9
ETP-15/16	23.81	34	49	40.0	25	39	44	4	M5	5.9
ETP-24	24	34	49	40.0	25	40	45	4	M5	5.9
ETP-25	25	34	49	40.0	27	43	48	4	M5	5.9
ETP-1	25.40	35	51	41.5	27	41	46	4	M5	5.9
ETP-28	28	39	55	46.0	29	45	50	4	M5	5.9
ETP-1-1/8	28.58	39	55	46.0	29	43	48	4	M5	5.9
ETP-30	30	41	57	47.5	32	47	52	4	M5	5.9
ETP-1-3/16	30.16	41	57	47.5	32	47	52	4	M5	5.9
ETP-1-1/4	31.75	43	60	50.5	34	50	55	4	M5	5.9
ETP-32	32	43	60	50.5	34	52	57	4	M5	5.9
ETP-1-3/8	34.93	47	63	53.5	37	53	58	6	M5	5.9
ETP-35	35	47	63	53.5	37	55	60	6	M5	5.9
ETP-1-7/16	36.51	50	65	56.0	37	54	59	6	M5	5.9
ETP-38	38	50	65	56.0	41	59	64	6	M5	5.9
ETP-1-1/2	38.10	52	68	59.0	41	57	62	6	M5	5.9
ETP-40	40	53	70	60.5	43	63	68	6	M5	5.9
ETP-1-5/8	41.28	55	70	61.0	44	63	68	6	M5	5.9
ETP-42	42	55	70	60.5	45	65	70	6	M5	5.9
ETP-1-3/4	44.45	59	77	66.5	49	67	73	6	M6	9.6
ETP-45	45	59	77	66.5	49	69	75	6	M6	9.6
ETP-48	48	62	80	69.5	52	73	79	6	M6	9.6
ETP-1-15/16	49.21	65	83	72.5	52	74	80	6	M6	9.6
ETP-50	50	65	83	72.5	53	76	82	6	M6	9.6
ETP-2	50.80	68	88	76.0	53	74	80	6	M6	9.6
ETP-55	55	71	88	78.0	58	82	88	8	M6	9.6
ETP-60	60	77	95	84.5	64	90	96	8	M6	9.6
ETP-2-1/2	63.50	84	107	93.0	62	86	94	6	M8	23.6
ETP-65	65	84	102	91.0	68	96	102	8	M6	9.6
ETP-70	70	90	113	99.0	72	99	107	6	M8	23.6
ETP-2-15/16	74.61	95	118	104	85	108	118	6	M8	23.6
ETP-75	75	95	118	104	85	114	122	6	M8	23.6
ETP-3	76.20	98	121	107	74	101	109	6	M8	23.6
ETP-80	80	100	123	109	90	120	128	6	M8	23.6
ETP-85	85	106	129	115	95	125	133	6	M8	23.6
ETP-90	90	112	135	121	100	133	141	8	M8	23.6
ETP-95	95	120	143	129	105	139	147	8	M8	23.6
ETP-100	100	125	148	134	110	145	153	8	M8	23.6
ETP-4	101.60	130	155	141	97	128	136	8	M8	23.6

Tt = Recommended tightening torque for actuation screw. \* L1 and L2 are valid before mounting. Dimensions subject to alterations without notice



## FEATURES

- Mounting and dismantling is fast.
- Shortened ETP-CLASSIC for mounting shorter hub components.
- Precision adjustment of the hub can be made during mounting.
- Low tightening torque and small number of screws makes mounting easy and quick.
- Excellent concentricity even after many mountings.
- Hexhead screws can also be used.
- Handles temperature range -22°F to +185°F.

## Dimensional Information

Model	Dimensions						Screws		
	d	D	D1	L	L1*	L2*	No.	Dim	Tt
	mm	mm	mm	mm	mm	mm			lb ft
ETP-S19	19	28	45	13	26	31	3	M5	5.9
ETP-S20	20	28	45	15	28	33	3	M5	5.9
ETP-S25	25	34	49	15	29	34	4	M5	5.9
ETP-S30	30	41	57	20	34	39	4	M5	5.9
ETP-S35	35	47	63	22	38	43	6	M5	5.9
ETP-S40	40	53	70	25	42	47	6	M5	5.9
ETP-S45	45	59	77	28	45	51	6	M6	9.6
ETP-S50	50	65	83	26	45	51	6	M6	9.6

Tt = Recommended tightening torque for actuation screw. \* L1 and L2 are valid before mounting. Dimensions subject to alterations without notice

## Performance Information

Model	Transmittable			Polar moment of inertia	Weight	Hub Bore Tolerance			Shaft Tolerance				
	T	FA	FR			Upper Limit	Lower Limit	Grade	Upper Limit	Lower Limit	Grade		
	lb ft	lbf	lbf									mm	mm
ETP-S19	39	1,124	1,304	1.07	0.33	28.021	-	28.000	H7	19.020	-	18.967	k6-h8*
ETP-S20	55	1,349	1,484	1.02	0.31	28.021	-	28.000	H7	20.000	-	19.948	h9
ETP-S25	89	2,248	2,383	1.59	0.37	34.025	-	34.000	H7	25.000	-	24.948	h9
ETP-S30	155	3,147	3,305	3.16	0.53	41.025	-	41.000	H7	30.000	-	29.948	h9
ETP-S35	243	4,271	4,226	5.46	0.71	47.025	-	47.000	H7	35.000	-	34.938	h9
ETP-S40	369	5,845	5,125	9.68	1.01	53.030	-	53.000	H7	40.000	-	39.938	h9
ETP-S45	516	6,969	6,047	15.09	1.26	59.030	-	59.000	H7	45.000	-	44.938	h9
ETP-S50	738	8,992	7,868	22.38	1.59	65.030	-	65.000	H7	50.000	-	49.938	h9

T = Transmittable torque when axial force is 0. FA = Transmittable axial force when torque is 0. FR = Maximum radial force during continuous operation. Maximum allowed bending torque = 15% of transmittable torque T. \* The tolerance grade k6-h8 is a range between the upper limit of the ISO grade k6 and the lower limit of the ISO grade h8. Note: if the shaft is machined to a strict k6 tolerance range the transmittable torque will increase by 20%.

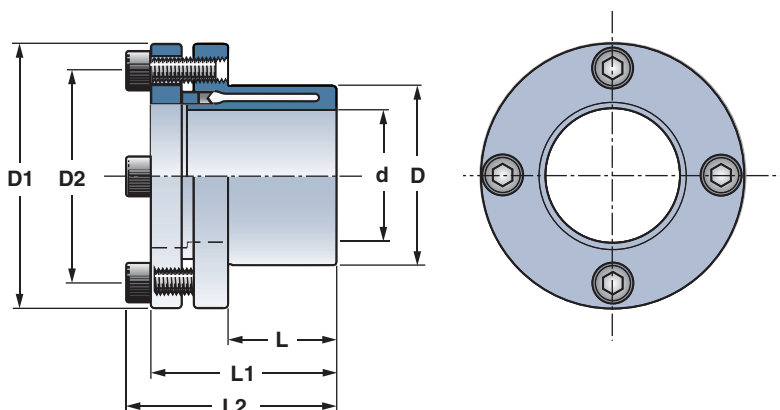

## DESIGN

ETP-CLASSIC S (short model) for applications requiring a smaller foot print. Same features as a standard ETP-CLASSIC. Consists of a double-walled hardened steel sleeve filled with a specially designed pressure medium, sealing ring, piston, pressure flange and clamping screws.

## OPERATION

When tightening the actuation screws, the sleeve expands uniformly against the hub and shaft and creates a rigid joint. When loosening the actuation screws the sleeve returns to its original measurements and can easily be dismantled.

**STAINLESS STEEL**



## FEATURES

- All parts exposed to the environment are made of stainless steel.
- Mounting and dismantling is fast.
- Precision adjustment of the hub can be made during mounting.
- Low tightening torque and small number of screws makes mounting easy and quick.
- Excellent concentricity even after many mountings.
- Hex head stainless steel screws.
- Handles temperature range -22°F to +185°F.

## Dimensional Information

Model	Dimensions							Screws		
	d	D	D1	D2	L	L1*	L2*	No.	Dim	Tt
	mm	mm	mm	mm	mm	mm	mm			lb ft
ETP-R15	15	23	38	28.5	17	30	34	4	M5	3.3
ETP-R20	20	28	45	35	22	37	41	5	M5	3.3
ETP-R25	25	34	49	40	27	43	47	7	M5	3.3
ETP-R30	30	41	57	47.5	32	47	51	7	M5	3.3
ETP-R35	35	47	63	53.5	37	55	59	9	M5	3.3
ETP-R40	40	53	70	60.5	43	63	67	9	M5	3.3
ETP-R45	45	59	77	66.5	49	69	73	9	M6	5.8
ETP-R50	50	65	83	72.5	53	76	80	9	M6	5.8

Tt = Recommended tightening torque for actuation screw. \* L1 and L2 are valid before mounting. Dimensions subject to alterations without notice

## Performance Information

Model	Transmittable			Polar moment of inertia	Weight	Hub Bore Tolerance			Shaft Tolerance		
	T	FA	FR			Upper Limit	Lower Limit	Grade	Upper Limit	Lower Limit	Grade
	lb ft	lbf	lbf			lb ft <sup>2</sup> x10 <sup>-3</sup>	lb	mm	mm	mm	mm
ETP-R15	33	1,349	562	0.45	0.22	23.021	- 23.000	H7	15.000	- 14.982	h7
ETP-R20	74	2,248	1,484	1.04	0.35	28.021	- 28.000	H7	20.000	- 19.967	h8
ETP-R25	155	3,777	2,383	1.66	0.46	34.025	- 34.000	H7	25.000	- 24.967	h8
ETP-R30	258	5,215	3,305	3.25	0.66	41.025	- 41.000	H7	30.000	- 29.967	h8
ETP-R35	369	6,407	4,226	5.55	0.90	47.025	- 47.000	H7	35.000	- 34.961	h8
ETP-R40	553	8,430	5,125	9.82	1.28	53.030	- 53.000	H7	40.000	- 39.961	h8
ETP-R45	811	10,970	6,047	15.35	1.63	59.030	- 59.000	H7	45.000	- 44.961	h8
ETP-R50	1,143	13,938	6,946	22.71	2.03	65.030	- 65.000	H7	50.000	- 49.961	h8

T = Transmittable torque when axial force is 0. FA = Transmittable axial force when torque is 0. FR = Maximum radial force during continuous operation. Maximum allowed bending torque = 15% of transmittable torque T.

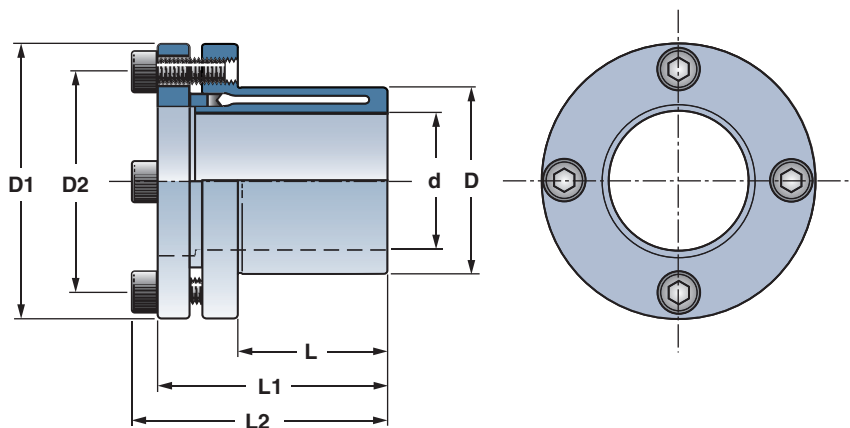

## DESIGN

ETP-CLASSIC R (stainless steel construction) are ideal for food and medical applications requiring frequent wash-downs. ETP-CLASSIC R consists of a double-walled hardened stainless steel sleeve and stainless hardware, filled with a specially designed food-grade pressure medium, sealing ring, piston, pressure flange and clamping screws.

## OPERATION

When tightening the actuation screws, the sleeve expands uniformly against the hub and shaft and creates a rigid joint. When loosening the actuation screws the sleeve returns to its original measurements and can easily be dismantled.



## FEATURES

- Fast and frequent mounting/dismantling with a single actuation screw.
- Radial screw positioning saves space along the shaft.
- Accurate positioning. No axial movement when mounting.
- Uniform surface pressure against shaft and hub prevents damage to surfaces and enables the use of small diameter hubs.
- Handles temperature range -22°F to 185°F.
- Excellent runout, ≤0.02 mm, even after several mountings.

## Performance Information

Model	Transmittable			Polar moment of inertia lb ft <sup>2</sup> x10 <sup>-3</sup>	Weight lb	Hub Bore Tolerance			Shaft Tolerance				
	T	FA	FR			Upper Limit	Lower Limit	Grade	Upper Limit	Lower Limit	Grade		
	lb ft	lbf	lbf			mm	mm		mm	mm			
ETP-E15	34	1,146	112	0.95	0.35	18.018	-	18.000	H7	15.000	-	14.982	h7
ETP-E5/8	39	1,236	112	1.19	0.37	19.018	-	19.000	H7	15.875	-	15.848	h8
ETP-E19	63	1,641	225	1.42	0.44	23.021	-	23.000	H7	19.020	-	18.979	k6-h7*
ETP-E3/4	63	1,641	225	1.42	0.44	23.021	-	23.000	H7	19.050	-	19.017	h8
ETP-E20	81	2,046	225	1.66	0.46	24.021	-	24.000	H7	20.000	-	19.967	h8
ETP-E22	96	2,158	270	2.37	0.55	27.021	-	27.000	H7	22.020	-	21.979	k6-h7*
ETP-E7/8	96	2,158	270	2.37	0.55	27.021	-	27.000	H7	22.225	-	22.192	h8
ETP-E24	140	2,922	315	2.61	0.60	29.021	-	29.000	H7	24.020	-	23.979	k6-h7*
ETP-E25	170	3,372	337	2.85	0.60	30.021	-	30.000	H7	25.000	-	24.967	h8
ETP-E1	140	2,698	337	3.08	0.64	31.025	-	31.000	H7	25.400	-	25.367	h8
ETP-E28	207	3,597	405	4.03	0.75	34.025	-	34.000	H7	28.020	-	27.979	k6-h7*
ETP-E1-1/8	214	3,597	405	4.27	0.77	35.025	-	35.000	H7	28.575	-	28.542	h8
ETP-E30	280	4,721	450	4.51	0.77	36.025	-	36.000	H7	30.000	-	29.967	h8
ETP-E1-1/4	317	4,946	495	5.93	0.93	39.025	-	39.000	H7	31.750	-	31.711	h8
ETP-E32	325	4,946	495	5.93	0.93	39.025	-	39.000	H7	32.020	-	31.975	k6-h7*
ETP-E1-3/8	472	6,744	562	7.59	1.06	42.025	-	42.000	H7	34.925	-	34.886	h8
ETP-E35	472	6,744	562	7.59	1.06	42.025	-	42.000	H7	35.000	-	34.961	h8
ETP-E1-7/16	546	7,418	584	8.54	1.15	44.025	-	44.000	H7	36.513	-	36.474	h8
ETP-E38	656	8,542	629	18.04	1.85	46.025	-	46.000	H7	38.020	-	37.975	k6-h7*
ETP-E1-1/2	656	8,542	629	18.04	1.85	46.025	-	46.000	H7	38.100	-	38.061	h8
ETP-E40	811	10,116	674	19.93	1.94	48.025	-	48.000	H7	40.000	-	39.961	h8
ETP-E42	811	9,666	719	23.02	2.12	51.030	-	51.000	H7	42.020	-	41.975	k6-h7*
ETP-E1-3/4*	1,033	11,465	787	28.48	2.42	54.030	-	54.000	H7	44.450	-	44.411	h8
ETP-E45	1,033	11,465	787	27.76	2.31	54.030	-	54.000	H7	45.000	-	44.961	h8
ETP-E48	1,254	12,814	899	34.65	2.67	59.030	-	59.000	H7	48.020	-	47.975	k6-h7*
ETP-E1-15/16*	1,401	14,162	967	37.26	2.80	60.030	-	60.000	H7	49.213	-	49.174	h8
ETP-E50	1,401	14,162	1,012	36.07	2.64	60.030	-	60.000	H7	50.000	-	49.961	h8
ETP-E2	1,401	13,938	1,012	40.82	2.82	61.030	-	61.000	H7	50.800	-	50.754	h8
ETP-E55	1,770	15,961	1,124	51.73	3.31	67.030	-	67.000	H7	55.021	-	54.970	k6-h7*
ETP-E60	2,434	20,232	1,191	75.23	4.08	73.030	-	73.000	H7	60.000	-	59.954	h8
ETP-E2-1/2*	2,950	23,604	1,214	88.75	4.50	77.030	-	77.000	H7	63.500	-	63.454	h8
ETP-E65	3,245	25,178	1,258	97.30	4.69	85.035	-	85.000	H7	65.000	-	64.954	h8
ETP-E70	4,130	29,224	1,439	168.96	6.70	85.035	-	85.000	H7	70.000	-	69.954	h8
ETP-E3*	5,531	35,968	1,574	213.81	7.67	91.035	-	91.000	H7	76.200	-	76.154	h8
ETP-E80	6,416	40,464	1,686	245.61	8.27	97.035	-	97.000	H7	80.000	-	79.954	h8
ETP-E90	8,850	49,456	1,933	360.70	10.58	109.035	-	109.000	H7	90.000	-	89.946	h8
ETP-E100	12,538	62,944	2,181	519.69	13.00	121.040	-	121.000	H7	100.000	-	99.946	h8

T = Transmittable torque when axial force is 0. FA = Transmittable axial force when torque is 0.

FR = Maximum radial force during continuous operation. Maximum allowed bending torque = 5% of transmittable torque T.

\* Indicated items are available but not included in standard production runs. If not in stock they are built to order. Contact factory with questions or for current price and lead-time quote.

## DESIGN

ETP-EXPRESS consists of a double-walled hardened steel sleeve and flange filled with a pressure medium. Located in the flange are one or two actuation screws and piston with seal, used to pressurize and maintain pressure in the connection.

## OPERATION

When the actuation screw is tightened, the double-walled sleeve expands uniformly against the shaft and hub and creates a rigid friction joint. Dismantling is done by loosening the screw which returns the ETP-Express to its original dimensions. It can then easily be dismantled.

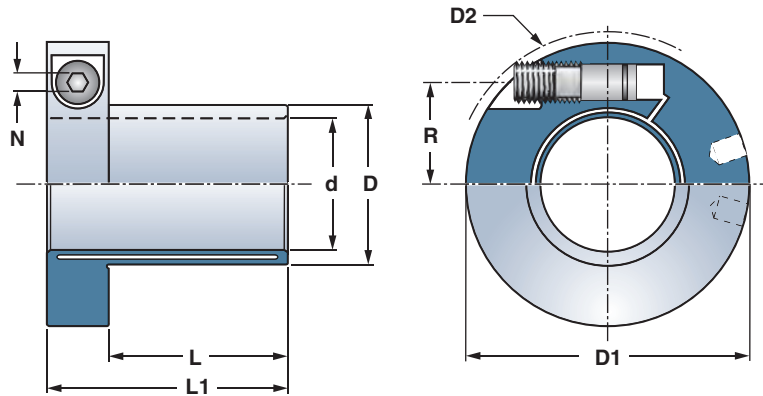

## Dimensional Information

Model	Dimensions						Screws			
	d mm	D mm	D1 mm	D2* mm	L mm	L1 mm	Dim.	R mm	N mm	Tt lb ft
ETP-E15	15	18	46.0	48.9	25	39	M10	15.1	5	3.69
ETP-E5/8	15.88	19	47.0	49.8	26	40	M10	15.6	5	3.69
ETP-E19	19	23	50.5	53.0	28	42	M10	17.4	5	3.69
ETP-E3/4	19.05	23	50.5	53.0	28	42	M10	17.4	5	3.69
ETP-E20	20	24	51.5	54.1	30	44	M10	18	5	3.69
ETP-E22	22	27	55.5	60.5	32	46	M10	19.3	5	3.69
ETP-E7/8	22.23	27	55.5	60.5	32	46	M10	19.3	5	3.69
ETP-E24	24	29	57.5	62.3	33	47	M10	20.3	5	3.69
ETP-E25	25	30	58.0	62.9	35	49	M10	20.8	5	3.69
ETP-E1	25.40	31	59.0	63.8	35	49	M10	21.2	5	3.69
ETP-E28	28	34	63.0	69.6	38	52	M10	22.6	5	3.69
ETP-E1-1/8	28.58	35	63.5	70.1	39	53	M10	23.0	5	3.69
ETP-E30	30	36	64.5	71.0	40	54	M10	23.6	5	3.69
ETP-E1-1/4	31.75	39	68.5	77.7	42	56	M10	24.8	5	3.69
ETP-E32	32	39	68.5	77.7	42	56	M10	24.8	5	3.69
ETP-E1-3/8	34.93	42	73.0	85.1	45	59	M10	26.4	5	3.69
ETP-E35	35	42	73.0	85.1	45	59	M10	26.4	5	3.69
ETP-E1-7/16	36.52	44	74.5	86.6	48	62	M10	27.3	5	3.69
ETP-E38	38	46	84.5	89.5	52	72	M16	31.0	8	15.49
ETP-E1-1/2	38.10	46	84.5	89.5	52	72	M16	31.0	8	15.49
ETP-E40	40	48	86.5	91.2	55	75	M16	32.0	8	15.49
ETP-E42	42	51	89.0	93.5	56	76	M16	33.2	8	15.49
ETP-E1-3/4	44.45	54	93.0	100.3	58	78	M16	34.8	8	15.49
ETP-E45	45	54	93.0	100.3	58	78	M16	34.8	8	15.49
ETP-E48	48	59	97.0	103.8	59	79	M16	36.8	8	15.49
ETP-E1-15/16	49.22	60	98.5	105.1	60	80	M16	37.5	8	15.49
ETP-E50	50	60	98.5	105.1	60	80	M16	37.5	8	15.49
ETP-E2	50.80	61	101.5	111.8	60	80	M16	38.0	8	15.49
ETP-E55	55	67	106.0	115.9	65	85	M16	40.5	8	15.49
ETP-E60	60	73	115.5	132.7	70	90	M16	43.3	8	15.49
ETP-E2-1/2	63.50	77	119.0	134.6	73	93	M16	45.1	8	15.49
ETP-E65	65	79	120.5	137.0	75	95	M16	46.1	8	21.00
ETP-E70	70	85	135.5	153.9	85	109	M20	50.5	10	28.76
ETP-E3	76.20	92	141.5	157.8	91	115	M20	54.1	10	28.76
ETP-E80	80	97	145.5	162.6	95	119	M20	56.3	10	28.76
ETP-E90	90	109	155.5	171.7	105	129	2 x M20**	61.8	10	28.76
ETP-E100	100	121	166.0	181.0	115	139	2 x M20**	67.3	10	28.76

Tt = Recommended tightening torque for actuation screw. Further tightening does not increase the pressure in the connection.  
 \* D2 is valid before mounting \*\* Pressure screws positioned in the same direction. Dimensions subject to alterations without notice

## STAINLESS STEEL



### FEATURES

- Fast and frequent mounting/dismantling with a single actuation.
- Radial screw positioning saves space along the shaft.
- Accurate positioning. No axial movement when mounting.
- Flat flange design allows for easy cleaning.
- Pressure medium and screw lubricant are food approved.
- All parts exposed to the environment are made of stainless steel.
- Uniform surface pressure against shaft and hub prevents damage to surfaces and enables the use of small diameter hubs.
- Handles temperature range -22°F to 185°F.
- Excellent runout,  $\leq 0.02$  mm, even after several mountings.

## Performance Information

Model	Transmittable			Polar moment of inertia lb ft <sup>2</sup> x10 <sup>-3</sup>	Weight lb	Hub Bore Tolerance			Shaft Tolerance				
	T lb ft	FA lbf	FR lbf			Upper Limit mm	Lower Limit mm	Grade	Upper Limit mm	Lower Limit mm	Grade		
ETP-ER15	34	1,146	112	0.95	0.35	18.018	-	18.000	H7	15.000	-	14.982	h7
ETP-ER5/8*	39	1,236	112	1.19	0.37	19.021	-	19.000	H7	15.875	-	15.848	h8
ETP-ER3/4	63	1,641	225	1.42	0.44	23.021	-	23.000	H7	19.050	-	19.017	h8
ETP-ER20	81	2,046	225	1.66	0.46	24.021	-	24.000	H7	20.000	-	19.967	h8
ETP-ER7/8	96	2,158	225	2.37	0.55	27.021	-	27.000	H7	22.225	-	22.192	h8
ETP-ER25	170	3,372	337	2.85	0.60	30.021	-	30.000	H7	25.000	-	24.967	h8
ETP-ER1	140	2,698	337	3.08	0.64	31.025	-	31.000	H7	25.400	-	25.367	h8
ETP-ER1-1/8*	214	3,597	405	4.27	0.77	35.025	-	35.000	H7	28.575	-	28.542	h8
ETP-ER30	280	4,721	450	4.51	0.77	36.025	-	36.000	H7	30.000	-	29.967	h8
ETP-ER1-1/4	317	4,946	495	5.93	0.93	39.025	-	39.000	H7	31.750	-	31.711	h8
ETP-ER1-3/8	472	6,744	562	7.36	1.04	42.025	-	42.000	H7	34.925	-	34.886	h8
ETP-ER35	472	6,744	562	7.59	1.06	42.025	-	42.000	H7	35.000	-	34.961	h8
ETP-ER1-1/2	656	8,542	629	18.04	1.85	46.025	-	46.000	H7	38.100	-	38.061	h8
ETP-ER40	811	10,116	674	19.93	1.94	48.025	-	48.000	H7	40.000	-	39.961	h8
ETP-ER1-3/4*	1,033	11,465	787	28.24	2.38	54.030	-	54.000	H7	44.450	-	44.411	h8
ETP-ER45	1,033	11,465	787	27.76	2.31	54.030	-	54.000	H7	45.000	-	44.961	h8
ETP-ER1-15/16*	1,401	14,162	1,012	36.78	2.76	60.030	-	60.000	H7	49.213	-	49.174	h8
ETP-ER50	1,401	14,162	1,012	36.07	2.64	60.030	-	60.000	H7	50.000	-	49.961	h8
ETP-ER2*	1,401	13,938	1,012	40.82	2.82	61.030	-	61.000	H7	50.800	-	50.754	h8
ETP-ER60	2,434	20,232	1,191	75.23	4.08	73.030	-	73.000	H7	60.000	-	59.954	h8
ETP-ER70*	4,130	29,224	1,439	168.96	6.70	85.035	-	85.000	H7	70.000	-	69.954	h8
ETP-ER80*	6,416	40,464	1,686	245.61	8.27	97.035	-	97.000	H7	80.000	-	79.954	h8

T = Transmittable torque when axial force is 0. FA = Transmittable axial force when torque is 0.

FR = Maximum radial force during continuous operation. Maximum allowed bending torque = 5% of transmittable torque T.

\* Indicated items are available but not included in standard production runs. If not in stock they are built to order. Contact factory with questions or for current price and lead-time quote.



ETP-EXPRESS R are available in stainless steel in most sizes. Also the pressure medium and screw lubricant are approved for use in the food industry.

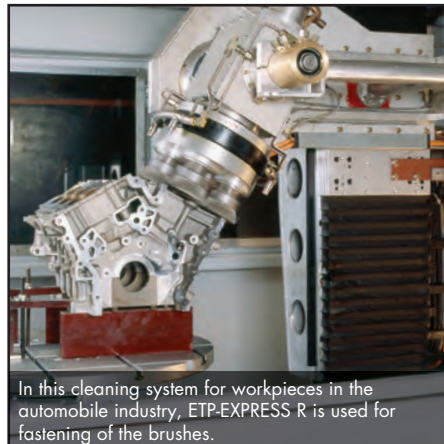

In this cleaning system for workpieces in the automobile industry, ETP-EXPRESS R is used for fastening of the brushes.



ETP-EXPRESS R is corrosion resistant and quick mounting and ideal for gear box shaft connections.

## DESIGN

ETP-EXPRESS R (stainless steel construction) consists of a double-walled hardened stainless steel sleeve and flange filled with a food-grade pressure medium. Located in the flange is a single actuation screw piston with seal, used to pressurize and maintain pressure in the connection.

## OPERATION

When the actuation screw is tightened, the double-walled sleeve expands uniformly against shaft and hub and creates a rigid friction joint. Dismantling is done by loosening the screw which returns the ETP-EXPRESS R to its original dimensions. It can then easily be dismantled.

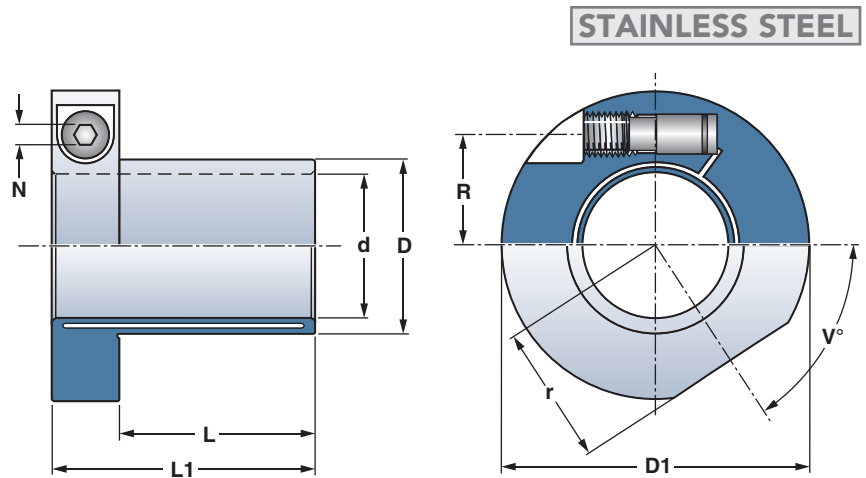

## Dimensional Information

Model	Dimensions								Screws			
	d	D	D1	D2*	L	L1	r	V°	Dim.	R	N	Tt
	mm	mm	mm	mm	mm	mm	mm	degrees		mm	mm	lb ft
ETP-ER15	15	18	46.0	48.9	25	39	19.9	53	M10	15.1	5	3.69
ETP-ER5/8	15.88	19	47.0	49.8	26	40	20.3	54	M10	15.6	5	3.69
ETP-ER3/4	19.05	23	50.5	53	28	42	21.9	55	M10	17.4	5	3.69
ETP-ER20	20	24	51.5	54.1	30	44	22.6	56	M10	18.0	5	3.69
ETP-ER7/8	22.23	27	55.5	60.5	32	46	24.4	57	M10	19.3	5	3.69
ETP-ER25	25	30	58.0	62.9	35	49	26.1	58	M10	20.8	5	3.69
ETP-ER1	25.40	31	59.0	63.8	35	49	25.8	58	M10	21.2	5	3.69
ETP-ER1-1/8	28.58	35	63.5	70.1	39	53	28.5	59	M10	23.0	5	3.69
ETP-ER30	30	36	64.5	71	40	54	29.1	59	M10	23.6	5	3.69
ETP-ER1-1/4	31.75	39	68.5	77.7	42	56	31.1	58	M10	24.8	5	3.69
ETP-ER1-3/8	34.93	42	73.0	85.1	45	59	31.9	60.5	M10	26.4	5	3.69
ETP-ER35	35	42	73.0	85.1	45	59	33.7	58	M10	26.4	5	3.69
ETP-ER1-1/2	38.10	46	84.5	89.5	52	72	36.6	58	M16	31.0	8	15.49
ETP-ER40	40	48	86.5	91.2	55	75	37.7	59	M16	32.0	8	15.49
ETP-ER1-3/4	44.45	54	93.0	100.3	58	78	41.1	59	M16	34.8	8	15.49
ETP-ER45	45	54	93.0	100.3	58	78	41.1	61	M16	34.8	8	15.49
ETP-ER1-15/16	49.22	60	98.5	105.1	60	80	43.7	60	M16	37.5	8	15.49
ETP-ER50	50	60	98.5	105.1	60	80	43.7	62	M16	37.5	8	15.49
ETP-ER2	50.80	61	101.5	111.8	60	80	45.2	60	M16	38.0	8	15.49
ETP-ER60	60	73	115.5	132.7	70	90	53.3	59	M16	43.3	8	15.49
ETP-ER70	70	85	135.5	153.9	85	109	62.0	59	M20	50.8	10	28.76
ETP-ER80	80	97	145.5	162.6	95	119	65.9	61	M20	56.3	10	28.76

Tt = Recommended tightening torque for actuation screw. Further tightening does not increase the pressure in the connection.  
 \* D2 is valid before mounting Dimensions subject to alterations without notice

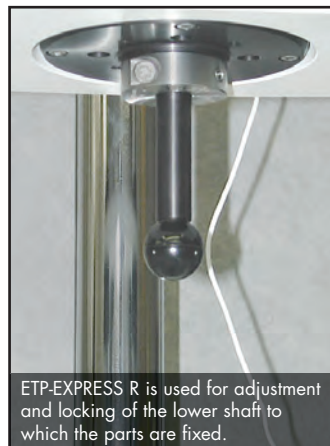
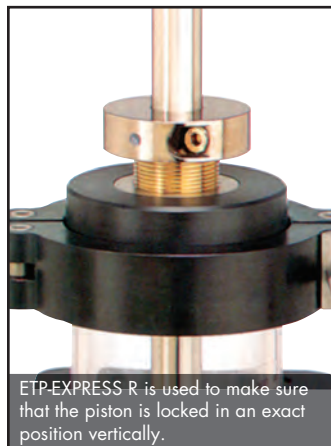



**FEATURES**

- Extremely fast mounting/dismantling with only one or two screws.
- Can be mounted/dismantled 1000's of times.
- Extremely good concentricity,  $\leq 0.006$  mm, even after several mountings.
- Dual sealing system.
- Radial tightening of the screw saves space along the shaft.
- Small built-in dimensions.
- Accurate positioning, no axial movement when mounting.
- Handles temperature range -22°F to 230°F.

**Performance Information**

Model	Transmittable			Polar moment of inertia lb ft <sup>2</sup> x10 <sup>-3</sup>	Weight lb	Hub Bore Tolerance			Shaft Tolerance				
	T	FA	FR			Upper Limit	Lower Limit	Grade	Upper Limit	Lower Limit	Grade		
	lb ft	lbf	lbf			mm	mm		mm	mm			
ETP-T15	37	1,124	225	2.14	0.55	19.018	-	19.000	H7	15.000	-	14.973	h8
ETP-T20	107	2,698	450	3.56	0.71	25.021	-	25.000	H7	20.000	-	19.967	h8
ETP-T25	184	3,597	674	9.02	1.28	32.021	-	32.000	H7	25.000	-	24.961	h8
ETP-T1*	184	3,597	674	9.02	1.28	32.021	-	32.000	H7	25.400	-	25.361	h8
ETP-T30	369	5,845	899	12.81	1.52	38.025	-	38.000	H7	30.000	-	29.961	h8
ETP-T1-1/4*	376	5,620	899	15.19	1.72	41.025	-	41.000	H7	31.750	-	31.711	h8
ETP-T32	376	5,620	899	15.19	1.72	41.025	-	41.000	H7	32.000	-	31.961	h8
ETP-T35	546	7,643	1,124	17.80	1.85	44.025	-	44.000	H7	35.000	-	34.961	h8
ETP-T1-1/2*	649	8,093	1,124	26.10	2.38	50.025	-	50.000	H7	38.100	-	38.061	h8
ETP-T40	885	10,566	1,349	30.85	2.60	52.025	-	52.000	H7	40.000	-	39.954	h8
ETP-T45	1,254	13,938	1,574	35.60	2.73	56.025	-	56.000	H7	45.000	-	44.954	h8
ETP-T50	1,659	15,961	2,023	54.58	3.62	65.025	-	65.000	H7	50.000	-	49.954	h8
ETP-T60	3,245	26,751	2,698	118.65	5.53	75.030	-	75.000	H7	60.000	-	59.954	h8
ETP-T70	5,163	35,518	2,922	211.20	8.05	90.030	-	90.000	H7	70.000	-	69.946	h8
ETP-T75	6,343	41,138	3,147	284.76	9.26	95.030	-	95.000	H7	75.000	-	74.946	h8
ETP-T80	8,039	49,006	3,372	355.96	10.69	100.030	-	100.000	H7	80.000	-	79.946	h8
ETP-T90	11,431	62,270	3,822	522.07	11.99	112.035	-	112.000	H7	90.000	-	89.946	h8
ETP-T100	15,488	75,308	4,271	783.10	13.62	125.035	-	125.000	H7	100.000	-	99.937	h8
ETP-T110	20,650	92,168	4,721	1,020.41	15.61	138.035	-	138.000	H7	110.000	-	109.937	h8
ETP-T120	21,388	88,346	5,170	1,281.44	21.96	150.035	-	150.000	H7	120.000	-	119.937	h8
ETP-T130	23,600	88,346	5,620	1,779.78	23.94	163.040	-	163.000	H7	130.000	-	129.937	h8

T = Transmittable torque when axial force is 0. FA = Transmittable axial force when torque is 0.

FR = Maximum radial force during continuous operation. Maximum allowed bending torque = 10% of transmittable torque T.

\* Indicated items are available but not included in standard production runs. If not in stock they are built to order. Contact factory with questions or for current price and lead-time quote.

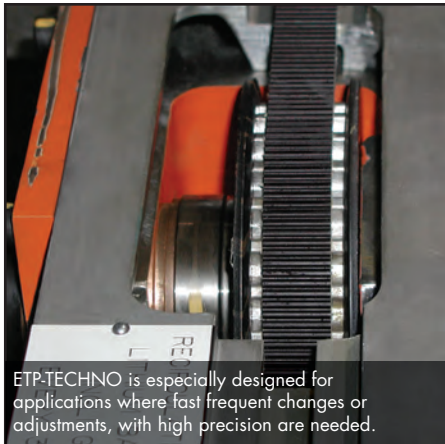

ETP-TECHNO is especially designed for applications where fast frequent changes or adjustments, with high precision are needed.

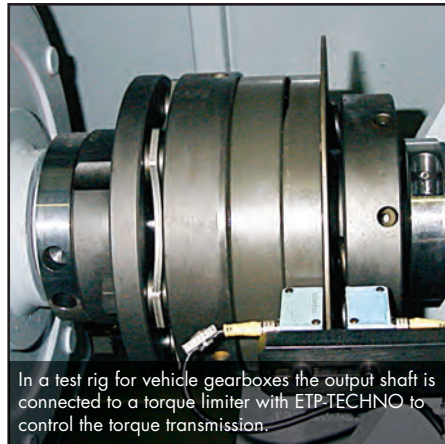

In a test rig for vehicle gearboxes the output shaft is connected to a torque limiter with ETP-TECHNO to control the torque transmission.

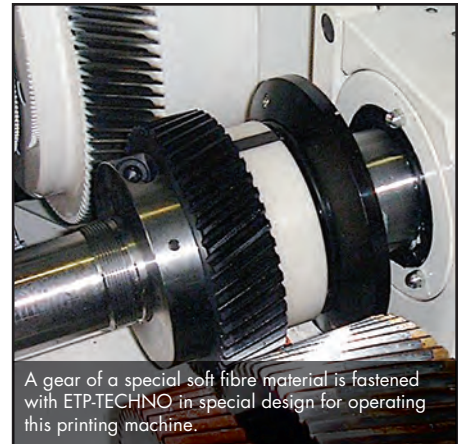

A gear of a special soft fibre material is fastened with ETP-TECHNO in special design for operating this printing machine.

## DESIGN

ETP-TECHNO consists of a double-walled hardened steel sleeve and flange filled with a pressure medium. Located in the flange are one or two actuation screws, piston with seal, used to pressurize and maintain pressure in the connection. The unique design of the piston provides a secondary sealing system which helps maintain bushing pressure.

## OPERATION

When the actuation screw is tightened, the double-walled sleeve expands uniformly against the shaft and hub and creates a rigid friction joint. Dismantling is done by loosening the screw which returns the ETP-TECHNO to its original dimensions. It can then easily be dismantled.

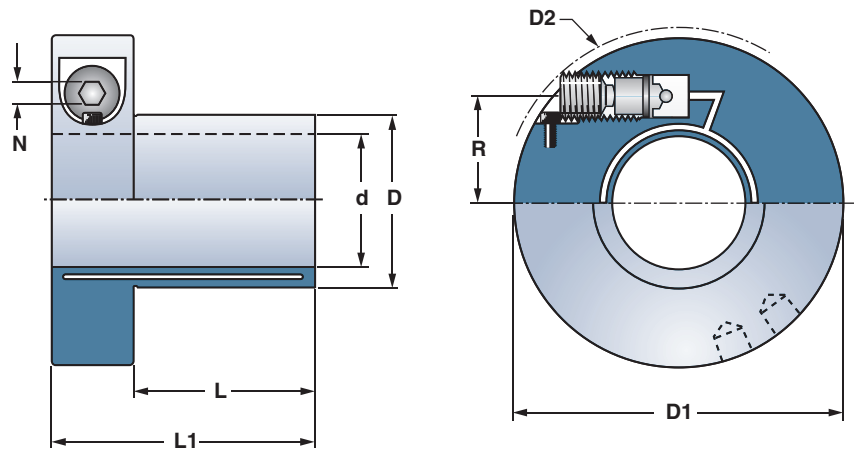

## Dimensional Information

Model	Dimensions						Screws			
	d mm	D mm	D1 mm	D2* mm	L mm	L1 mm	Dim.	R mm	N mm	Tt lb ft
ETP-T15	15	19	52	53	25	41	M12	16.0	6	7
ETP-T20	20	25	59	60	30	46	M12	19.0	6	7
ETP-T25	25	32	70	71	35	55	M14	24.0	6	12
ETP-T1	25.40	32	70	71	35	55	M14	24.0	6	12
ETP-T30	30	38	75	79	40	60	M14	26.0	6	12
ETP-T1-1/4	31.75	41	79	81	42	62	M14	27.5	6	12
ETP-T32	32	41	79	81	42	62	M14	27.5	6	12
ETP-T35	35	44	84	87	45	65	M16	29.5	8	18
ETP-T1-1/2	38.10	50	90	93	50	70	M16	32.5	8	18
ETP-T40	40	52	91	95	55	75	M16	33.0	8	18
ETP-T45	45	56	96	101	58	78	M16	35.0	8	18
ETP-T50	50	65	110	114	60	85	M20	40.9	10	30
ETP-T60	60	75	125	132	70	95	M20	46.8	10	30
ETP-T70	70	90	140	149	85	110	M20	53.0	10	30
ETP-T75	75	95	147	158	90	115	M20	55.3	10	30
ETP-T80	80	100	156	168	95	123	M22	58.7	10	44
ETP-T90	90	112	166	180	105	133	2 x M22**	63.3	10	44
ETP-T100	100	125	177	192	115	143	2 X M22**	69.6	10	44
ETP-T110	110	138	187	202	125	153	2 X M22**	75.1	10	44
ETP-T120	120	150	198	217	135	163	2 X M22**	80.9	10	37
ETP-T130	130	163	208	226	135	163	2 X M22**	86.3	10	34

Tt = Recommended tightening torque for actuation screw. Further tightening does not increase the pressure in the connection.  
 \* D2 is valid before mounting \*\* Pressure screws positioned in the same direction. Dimensions subject to alterations without notice



ETP-TECHNO fastens the boring equipment in the front of this mobile boring machine.



ETP-TECHNO provides flexible mounting for gear built into the drive line of printing press.

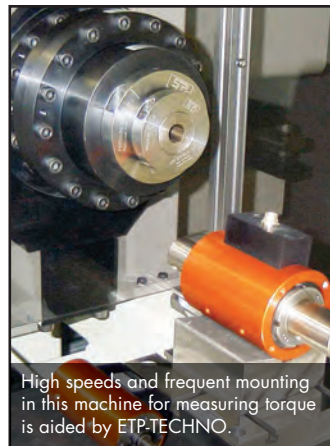

High speeds and frequent mounting in this machine for measuring torque is aided by ETP-TECHNO.



ETP-TECHNO provides accurate setting for spiral knives in relation to each other and quick changeout.



## FEATURES

- High radial load capacity.
- Fast mounting/dismantling with only one screw.
- Small built-in dimensions.
- Radial tightening of the screw saves space along the shaft.
- Accurate positioning, no axial movement when mounting.
- Excellent concentricity even after several mountings.
- Handles temperature range 32°F to 158°F.

## Performance Information

Model	Transmittable			Polar moment of inertia lb ft <sup>2</sup> x10 <sup>-3</sup>	Weight lb	Hub Bore Tolerance			Shaft Tolerance				
	T lb ft	FA lbf	FR lbf			Upper Limit mm	Lower Limit mm	Grade	Upper Limit mm	Lower Limit mm	Grade		
ETP-P15	44	1,574	450	1.42	0.42	20.021	-	20.000	H7	15.000	-	14.973	h8
ETP-P19	74	1,798	899	1.90	0.51	26.021	-	26.000	H7	19.015	-	18.979	k6-h7*
ETP-P3/4	74	1,798	899	1.90	0.51	26.021	-	26.000	H7	19.050	-	19.017	h8
ETP-P20	96	2,473	899	2.14	0.53	27.021	-	27.000	H7	20.000	-	19.967	h8
ETP-P22	155	3,372	1,079	2.61	0.60	29.021	-	29.000	H7	22.015	-	21.979	k6-h7*
ETP-P24	170	3,372	1,259	4.03	0.75	32.025	-	32.000	H7	24.015	-	23.979	k6-h7*
ETP-P25	221	4,496	1,349	4.98	0.84	33.025	-	33.000	H7	25.000	-	24.967	h8
ETP-P1	221	4,496	1,349	4.98	0.84	33.025	-	33.000	H7	25.400	-	25.367	h8
ETP-P28	240	4,496	1,619	6.17	0.95	37.025	-	37.000	H7	28.015	-	27.979	k6-h7*
ETP-P30	391	5,845	1,798	6.88	0.99	39.025	-	39.000	H7	30.000	-	29.967	h8
ETP-P1-1/4	406	5,845	1,978	17.32	1.81	43.025	-	43.000	H7	31.750	-	31.711	h8
ETP-P32	406	5,845	1,978	17.32	1.81	43.025	-	43.000	H7	32.018	-	31.975	k6-h7*
ETP-P35	664	8,992	2,248	20.17	1.94	46.025	-	46.000	H7	35.000	-	34.961	h8
ETP-P38	848	10,566	2,518	22.31	2.03	50.025	-	50.000	H7	38.018	-	37.975	k6-h7*
ETP-P1-1/2	848	10,566	2,518	22.31	2.03	50.025	-	50.000	H7	38.100	-	38.061	h8
ETP-P40	885	10,566	2,698	23.73	2.20	53.030	-	53.000	H7	40.000	-	39.961	h8
ETP-P1-3/4	1,180	15,737	3,147	30.85	2.87	58.030	-	58.000	H7	44.450	-	44.411	h8

T = Transmittable torque when axial force is 0. FA = Transmittable axial force when torque is 0.

FR = Maximum radial force during continuous operation. Maximum allowed bending torque = 10% of transmittable torque T.

\* The tolerance grade k6-h7 is a range between the upper limit of the ISO grade k6 and the lower limit of the ISO grade h7.

Note: ETP-POWER bushings are not included in standard production runs. If not in stock they are built to order. Contact factory with questions or for current price and lead-time quote.

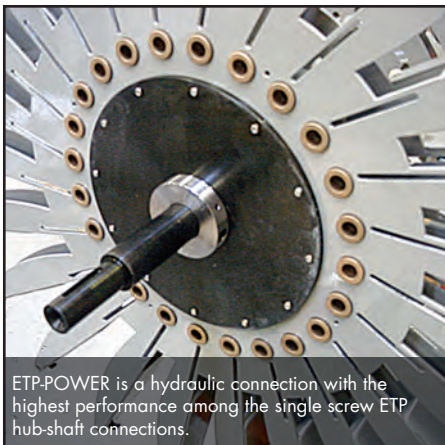

## DESIGN

ETP-POWER consists of a double-walled hardened steel sleeve and flange filled with a specially designed pressure medium. The flange contains a single actuation screw piston with seal that are used to pressurize and maintain pressure in the connection. Also in the flange are two pre-machined bores that can be used to attach ETP-POWER to the mounted components when the connection is not pressurized.

## OPERATION

When the actuation screw is tightened, the double-walled sleeve expands uniformly against the shaft and hub and creates a rigid friction joint. Dismantling is done by loosening the screw which returns the ETP-POWER to its original dimensions. It can then easily be dismantled.

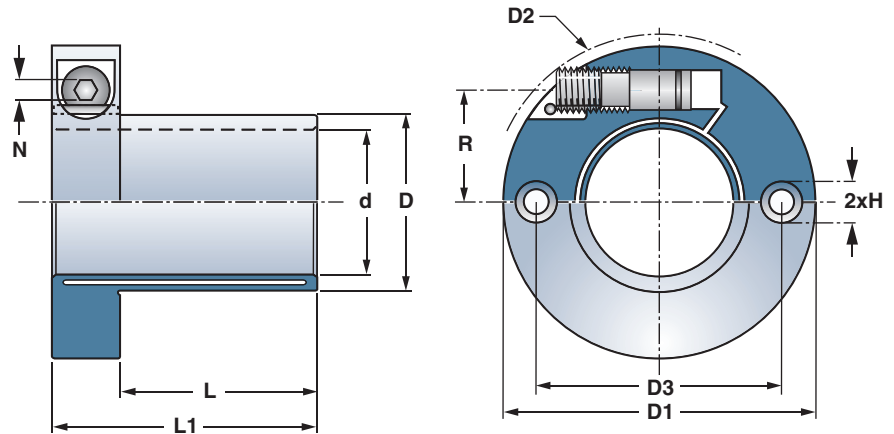

## Dimensional Information

Model	Dimensions						Screws				Bores 2xH suitable for MC6S screws	
	d mm	D mm	D1 mm	D2* mm	L mm	L1 mm	Dim.	R mm	N mm	Tt Nm	D3 mm	Screw Dim.
ETP-P15	15	20	51	55	21	35	M10	17.1	5	8	36.0	M5
ETP-P19	19	26	54	58	27	41	M10	18.2	5	8	40.0	M5
ETP-P3/4	19.05	26	54	58	27	41	M10	18.2	5	8	40.0	M5
ETP-P20	20	27	55	59	28	42	M10	18.9	5	8	41.0	M5
ETP-P22	22	29	58	62	29	43	M10	20.5	5	8	41.0	M5
ETP-P24	24	32	64	70	33	47	M10	22.7	5	8	48.0	M6
ETP-P25	25	33	67	72	34	48	M10	23.2	5	8	50.0	M6
ETP-P1	25.40	33	67	72	34	48	M10	23.2	5	8	50.0	M6
ETP-P28	28	37	70	76	35	49	M10	24.9	5	8	53.5	M6
ETP-P30	30	39	72	80	36	50	M10	26.0	5	8	55.5	M6
ETP-P1-1/4	31.75	43	85	92	38	58	M16	31.0	8	25	64.5	M8
ETP-P32	32	43	85	92	38	58	M16	31.0	8	25	64.5	M8
ETP-P35	35	46	88	94	40	60	M16	32.4	8	25	67.0	M8
ETP-P38	38	50	90	96	44	64	M16	33.1	8	25	70.0	M8
ETP-P1-1/2	38.10	50	90	96	44	64	M16	33.1	8	25	70.0	M8
ETP-P40	40	53	91	96	47	67	M16	34.2	8	25	72.0	M8
ETP-P1-3/4	44.45	58	103	114	51	71	M16	37.9	8	25	80.5	M8

Tt = Recommended tightening torque for actuation screw. Further tightening does not increase the pressure in the connection.  
 \* D2 is valid before mounting \*\* Pressure screws positioned in the same direction. Dimensions subject to alterations without notice

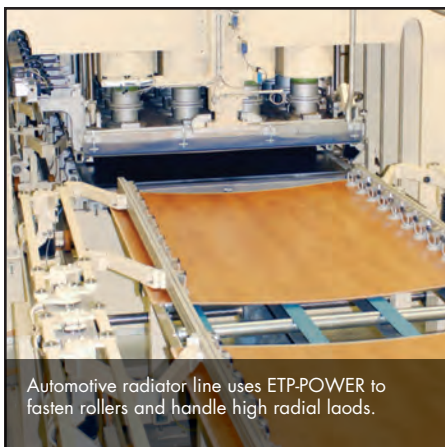

Automotive radiator line uses ETP-POWER to fasten rollers and handle high radial loads.

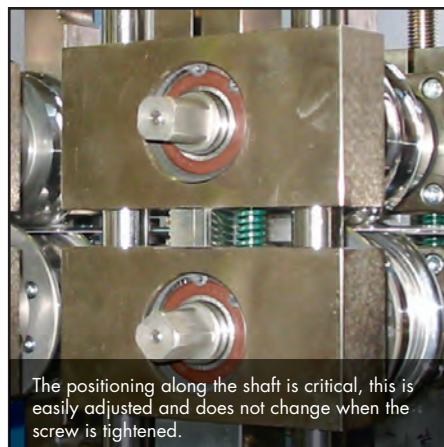

The positioning along the shaft is critical, this is easily adjusted and does not change when the screw is tightened.



Rollers are easily changed using ETP-POWER and especially beneficial in high production applications.



## FEATURES

- High transmittable torque capacity - can be varied by changing the mounting pressure.
- Very high radial load capacity.
- Fast mounting/dismantling in tight spaces.
- Radial and axial connection is possible.
- Fine adjustments of the hub can be made when mounting.
- Good concentricity even after several mountings.
- With ETP-HFC coating – double torque capacity.

## CONSTRUCTION

ETP-HYLOC is a hydro-mechanical joint, which consists of a double-walled steel sleeve which encloses a conical moveable piston. Mounting and dismantling is carried out with an external hydraulic pump (supplied separately). In the flange there are three threaded connections ("ON", "P", and "OFF") in the radial direction and the same in the axial. This makes it possible to choose radial or axial connection of the pump hoses, depending on the build-in situation.

## OPERATION

When the piston is moved, by the hydraulic pressure from the pump, the double-walled sleeve expands uniformly against shaft and hub to form a rigid joint. When dismantling, the piston is moved in the opposite direction and the joint will loosen. A small amount of oil will be taken via spiral tracks in the piston between the surfaces (pressure applied through the "P" connection), in this way making it easier for the piston to move. Normal working pressure is 1,000 bar. Other pressures can be used - consult with the factory.

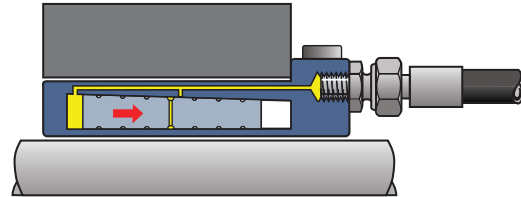

*Mounting: apply pressure in the "ON" and "P" (not shown) connections. When mounted no hydraulic pressure remains. The small conical angle prevents the piston from releasing.*

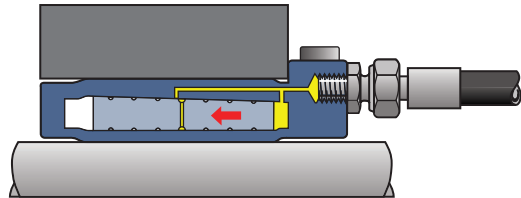

*Dismantling: apply pressure in the "OFF" and "P" (not shown) connections. ETP-HYLOC returns to its original measurements and the joint is loose.*

## Performance Information

Model	Transmittable torque or axial forces at 1,000 bar / 14,500 psi*				Hub Bore Tolerance			Shaft Tolerance				
	Shaft h7		Min hub DH mm		Upper Limit	Lower Limit	Grade	Upper Limit	Lower Limit	Grade		
	T	FA	Yieldpoint psi									
	lb ft	lbf	>43,511	>58,015	mm	mm		mm	mm			
ETP-HY50	1,918	15,736	110	105	77.030	-	77.000	H7	50.000	-	49.975	h7
ETP-HY60	3,319	29,224	140	125	89.035	-	89.000	H7	60.000	-	59.970	h7
ETP-HY70	5,826	47,208	170	145	102.035	-	102.000	H7	70.000	-	69.970	h7
ETP-HY80	8,924	65,192	200	160	115.035	-	115.000	H7	80.000	-	79.970	h7
ETP-HY90	12,611	85,424	235	180	128.040	-	128.000	H7	90.000	-	89.965	h7
ETP-HY100	17,848	109,028	270	200	140.040	-	140.000	H7	100.000	-	99.965	h7
ETP-HY110	24,264	133,756	295	220	154.040	-	154.000	H7	110.000	-	109.965	h7
ETP-HY120	31,860	161,856	320	240	168.040	-	168.000	H7	120.000	-	119.965	h7
ETP-HY130	39,678	185,460	350	260	182.046	-	182.000	H7	130.000	-	129.960	h7
ETP-HY140	50,814	221,428	375	280	196.046	-	196.000	H7	140.000	-	139.960	h7
ETP-HY150	62,983	255,148	400	300	210.046	-	210.000	H7	150.000	-	149.960	h7
ETP-HY160	76,700	293,364	425	320	224.046	-	224.000	H7	160.000	-	159.960	h7
ETP-HY180	110,625	376,540	480	360	252.052	-	252.000	H7	180.000	-	179.960	h7
ETP-HY200	151,925	463,088	535	400	280.052	-	280.000	H7	200.000	-	199.954	h7
ETP-HY220	201,338	558,628	585	435	308.052	-	308.000	H7	220.000	-	219.954	h7

T = Transmittable torque when axial force is 0. FA = Transmittable axial force when torque is 0. DH = Minimum hub outer diameter in steel.

\* Pressures between 600-1,200 bar can be used with different transmittable torque than shown in above chart. Contact the factory for ratings at different mounting pressures.

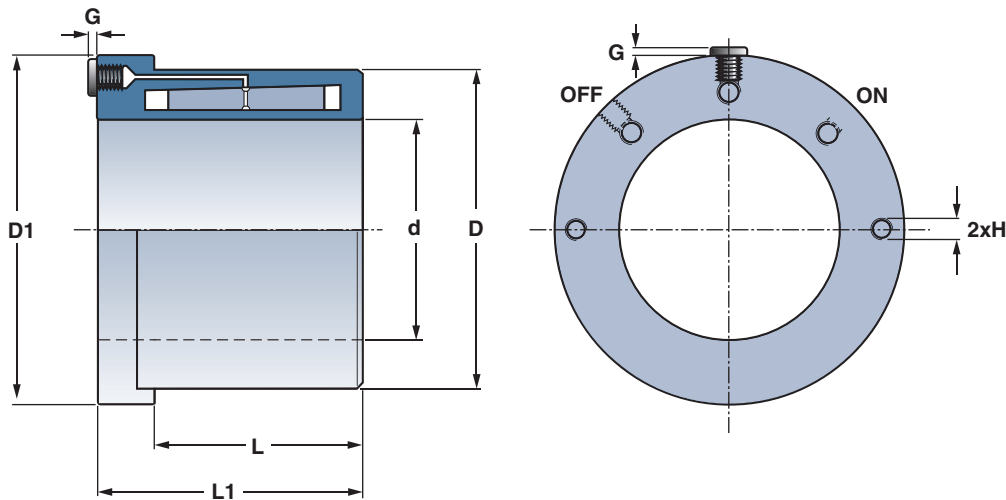

**Dimensional Information**

Model	Dimensions							Polar moment of inertia lb ft <sup>2</sup> x10 <sup>-3</sup>	Weight lb
	d mm	D mm	D1 mm	L mm	L1 mm	G mm	H		
ETP-HY50	50	77	101	56	82	7	M8	75.94	5.29
ETP-HY60	60	89	113	64	90	7	M8	128.14	6.83
ETP-HY70	70	102	122	74	100	7	M8	206.45	9.04
ETP-HY80	80	115	135	84	110	7	M8	332.23	11.90
ETP-HY90	90	128	148	94	120	7	M12	545.80	15.43
ETP-HY100	100	140	160	104	130	7	M12	806.83	18.95
ETP-HY110	110	154	173	114	140	7	M12	1,210.25	24.24
ETP-HY120	120	168	186	124	150	7	M12	1,803.51	30.86
ETP-HY130	130	182	200	134	160	7	M16	2,610.34	37.47
ETP-HY140	140	196	213	144	170	7	M16	3,559.55	46.28
ETP-HY150	150	210	227	154	180	7	M16	4,983.38	55.10
ETP-HY160	160	224	240	164	190	7	M16	6,881.80	66.12
ETP-HY180	180	252	267	184	210	7	M16	11,865.18	92.57
ETP-HY200	200	280	293	204	230	7	M16	19,696.20	123.42
ETP-HY220	220	308	320	224	250	7	M16	30,849.47	160.89

H = threaded holes for easy handling. Dimensions subject to alterations without notice

**Additional Information**

- If your application requires higher torque values, please contact the factory. With modification, we can increase the torque transmission up to two times the catalog values.
- Larger sizes are available upon request, please contact the factory.
- The values published are for hub materials that are made from steel. Please consult the factory if you wish to use other hub material.

**Mounting Advice**

- The contact surfaces L and L1 must be completely covered by the shaft and hub.
- Make sure mounting surfaces, shaft, and hub are clean and have good surface finish.
- The oil for the pump should be a transmission oil type 80 W.
- The mounting pressure is normally 1,000 bar. Lower pressures can be used, however, lower pressures will result in lower torque values. Please consult factory for the details.
- Maximum mounting pressure is 1,200 bar.
- Dismantling requires approx. 200 bar higher pressure than for mounting.

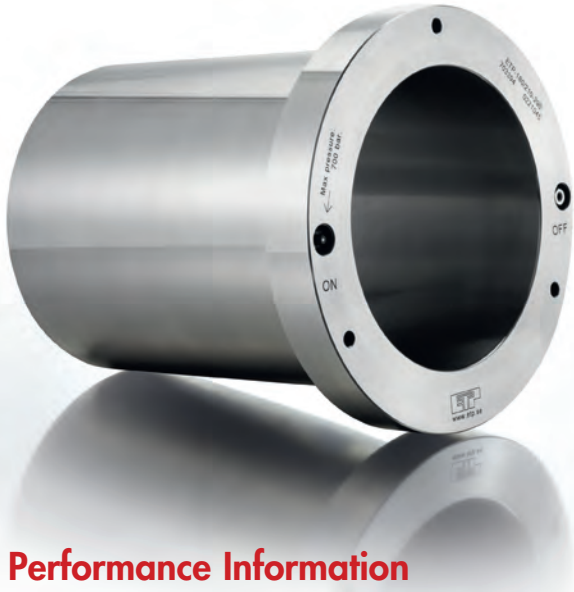

## FEATURES

- Variable transmittable torque or axial force by changing the mounting pressure.
- Easy mounting/dismantling of large components in tight spaces.
- Quick mounting. Only a grease pump is necessary for mounting.
- Radial and axial connection is possible.
- Fine adjustments of the hub can be made when mounting.
- Good concentricity even after several mountings.

## Performance Information

Model	Transmittable		Bore Tolerance			Shaft Tolerance				
	T lb ft	FA lbf	Upper Limit mm	Lower Limit mm	Grade	Upper Limit mm	Lower Limit mm	Grade		
ETP-HP160	2,139	6,969	187.046	-	187.000	H7	160.000	-	159.960	h7
ETP-HP180	3,393	9,846	210.046	-	210.000	H7	180.000	-	179.960	h7
ETP-HP200	4,720	12,297	234.046	-	234.000	H7	200.000	-	199.954	h7
ETP-HP220	6,711	15,916	257.052	-	257.000	H7	220.000	-	219.954	h7
ETP-HP240	8,850	19,625	275.052	-	275.000	H7	240.000	-	239.954	h7
ETP-HP260	11,800	24,054	298.052	-	298.000	H7	260.000	-	259.948	h7
ETP-HP280	15,488	29,224	323.057	-	323.000	H7	280.000	-	279.948	h7
ETP-HP300	19,913	35,968	338.057	-	338.000	H7	300.000	-	299.948	h7

T = Transmittable torque when axial force is 0. FA = Transmittable axial force when torque is 0. Transmittable torque and axial force are based on a mounting pressure of 600 bar/8,700 psi.

## Dimensional Information

Model	Dimensions						
	d mm	D mm	D1 mm	D2 mm	L mm	L1 mm	
ETP-HP160	160	187	235	203	125	160	
ETP-HP180	180	210	256	225	145	180	
ETP-HP200	200	234	278	247	165	200	
ETP-HP220	220	257	300	268	185	220	
ETP-HP240	240	275	319	287	205	240	
ETP-HP260	260	298	340	309	225	260	
ETP-HP280	280	323	364	332	245	280	
ETP-HP300	300	338	380	349	264	300	

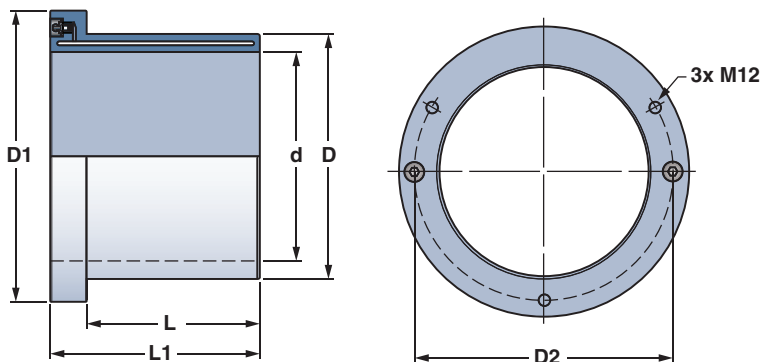

## DESIGN

ETP-HYDROPRESS is a hydraulic joint which consists of a double-walled steel sleeve. A hydraulic grease pump is required for mounting.

## OPERATION

When the hydraulic pressure from the pump is injected into the ETP-HYDROPRESS the double walled sleeve expands the inner and outer wall of the connection creating a rigid friction joint.



## ETP-KN® Knife Holder

### FEATURES

- Extremely fast mounting/dismantling with only one screw.
- Can be mounted/dismantled 1000's of times.
- Extremely good concentricity,  $\leq 0.006$  mm, even after several mountings.
- Radial tightening of the screw saves space along the shaft.
- Accurate positioning, no axial movement when mounting.

### DESIGN

ETP-KN is designed to expand only against the shaft and is used for fastening circular knives for slitting thin steel plates when manufacturing beverage and food cans. ETP-KN is only made to customer's specification. Shaft dimensions 50 – 200 mm.

### OPERATION

When the actuation screw is tightened, the double-walled sleeve expands uniformly against shaft and creates a rigid friction joint. Dismantling is done by loosening the screw which returns the ETP-KN to its original dimensions. It can then easily be dismantled.

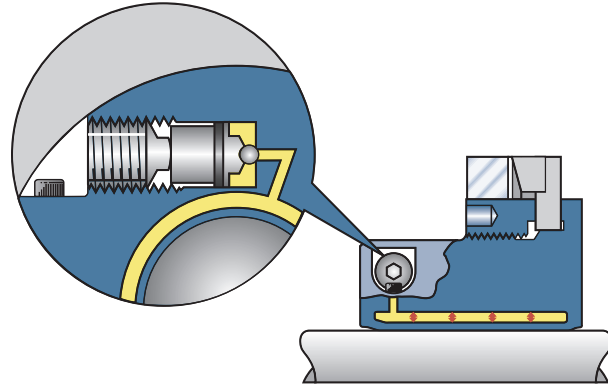
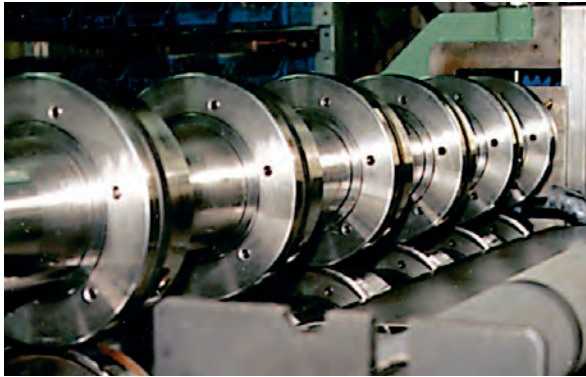

## ETP-UNIGRIP®

ETP-UNIGRIP is an axial tensioner used, for example, in the clamping of workpieces and tools against a shoulder on the shaft.

ETP-UNIGRIP has two separate hydraulic functions. When tightening the screw (R), ETP-UNIGRIP grips to the shaft. When tightening screw, (A), 3 pistons are pressurized which creates a high axial force (20 kN) against the components which are going to be clamped.

ETP-UNIGRIP is available in a limited range of standard sizes for shafts 35 – 65 mm.

More information can be sent on request. Special versions also with threaded inner diameter can be offered.

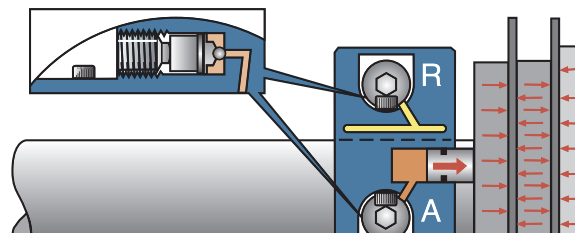

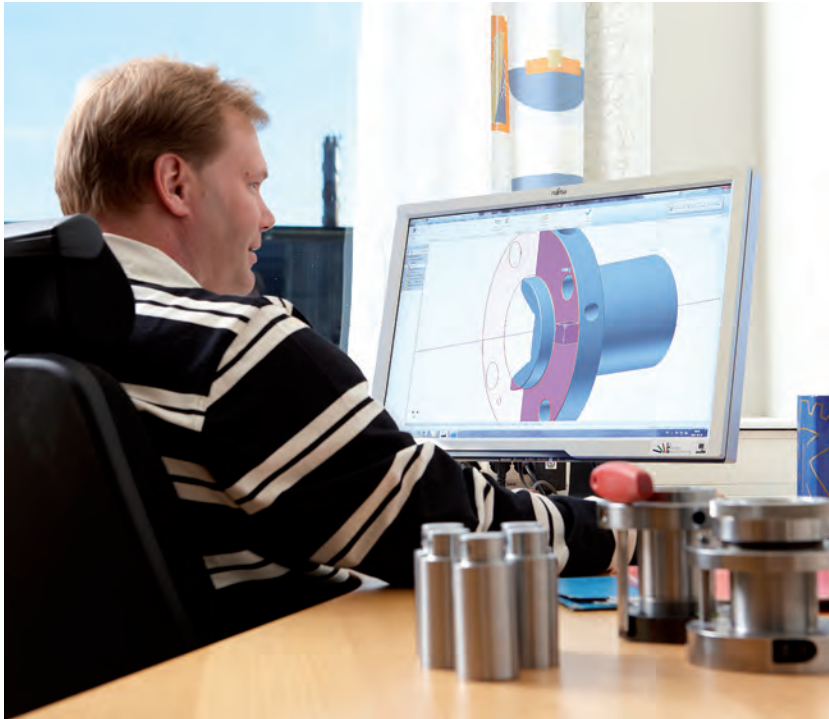

For over 70 years, Zero-Max, Inc. has created innovative solutions to servo motion control problems worldwide such as keyless lock bushings, shaft couplings and adjustable speed drives. With strategic distribution points located throughout the world, Zero-Max can deliver your motion control solution. The Zero-Max team of application specialists can engineer a solution to meet your motion control requirements.

The Zero-Max brand is known throughout the world as a mark of quality and performance. It is not uncommon for us to receive a call from a customer who has had one of our products in service for decades.

We enjoy talking to our customers and helping solve difficult applications. With many years of application experience we excel in this area of customer service.

- Experienced practical advice
- Responsive to our customers needs
- Predictable high quality
- Fast delivery
- Integrity
- High value
- ISO 9001:2015 certified

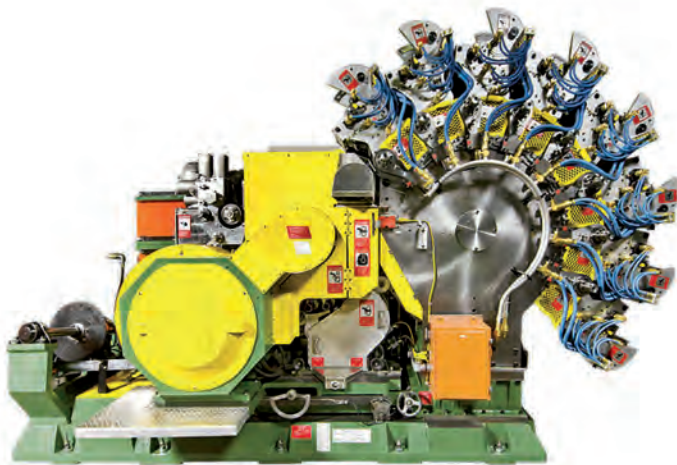

This customized ETP-AXPRESS fastens and centers the decorating cylinder for printing on the outside of beverage cans.

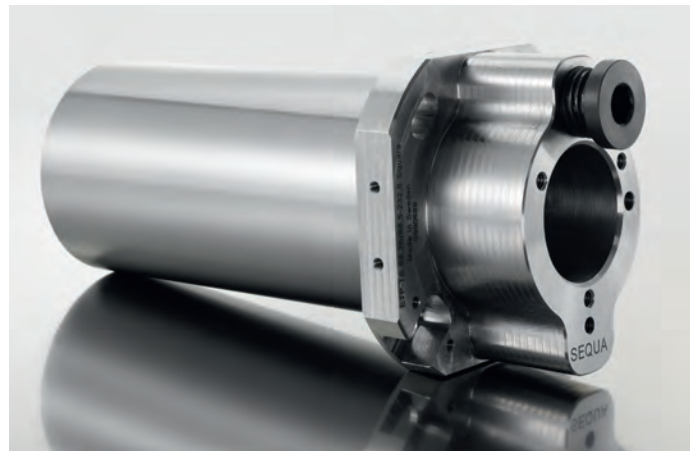

ETP-AXPRESS (a version of ETP-EXPRESS where the pressure setting is done in the axial direction). Decorator for 2 piece beverage cans.

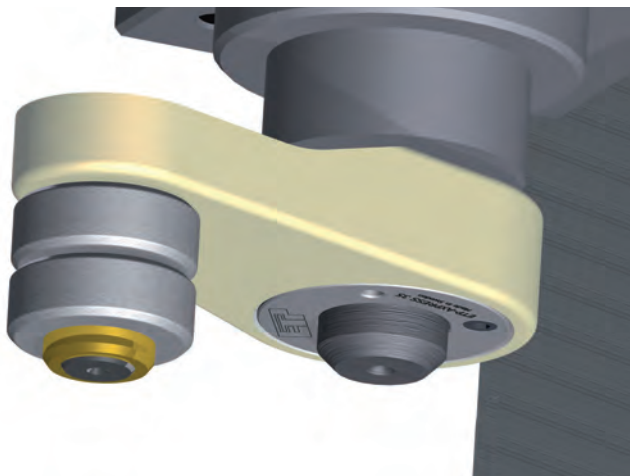

The lever is fastened with ETP-AXPRESS which clamps to the shaft when the screw is tightened.

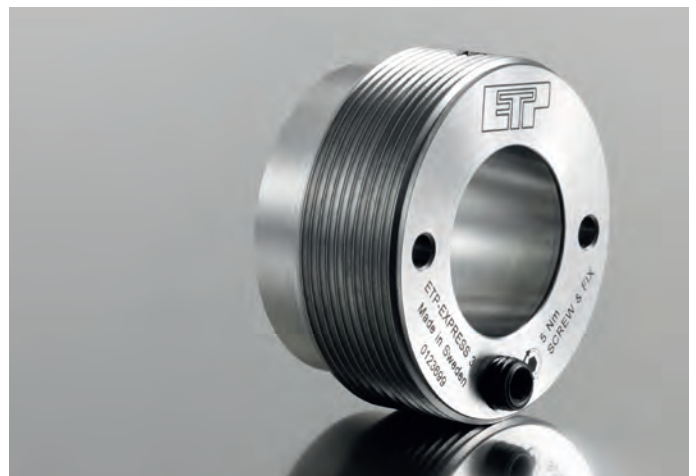

This lever is used for quick and accurate opening/closing of the blow molder for production of PET bottles.



Some customers tested the ETP solution for a few years, before finally the manufacturer started to use it for new machines.

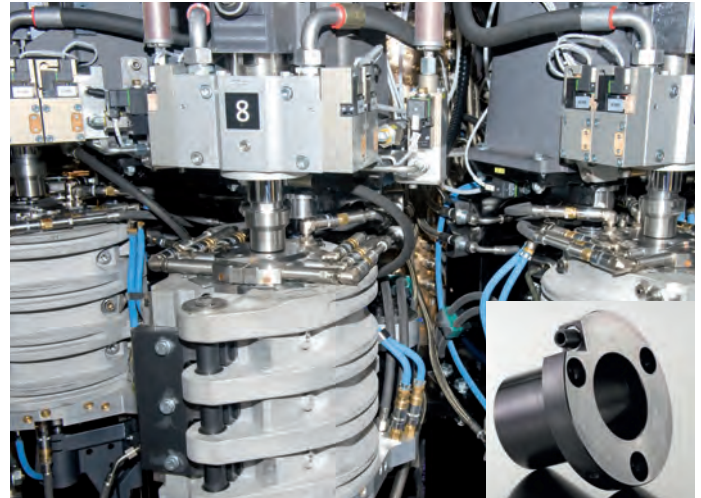

Complete blow mold unit with several molds/cavities.



ETP-HYCON is a hydromechanical coupling used in the steel/paper or other heavy industries where the requirements are for high performance, compact design, low weight, low inertia, high rigidity and reduced down time for maintenances.



ETP-OCTOPUS is used to lock machine parts that need to be repositioned frequently. Linear repositioning can be done frequently with high precision along the shaft. Actuation is done with an external pressure source.

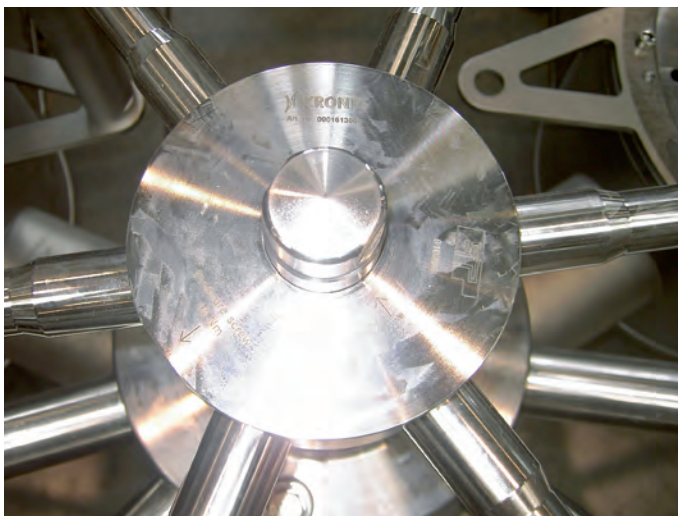

This ETP-EXPRESS R is made of high grade stainless steel, because it is washed regularly with an aggressive cleaning fluid.

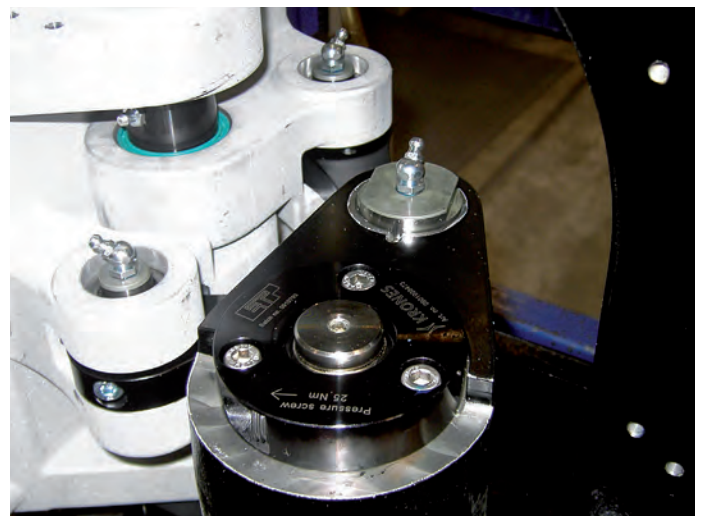

Lever fastened with ETP-EXPRESS to open/close the mold.

## Transmittable Torque

The ETP connections are tubular and create a surface pressure on to the shaft and the hub. Through the friction resistance both axial forces and torques can be transmitted. The amount will be determined by the area of the contact length ( $L_s$ ), the surface pressure and the coefficient of friction ( $\mu$ ).

The following formula is valid:  $T = p \cdot \frac{\pi d^2}{2} \cdot L_s \cdot \mu$

$L_s$  = the contact length.

$p$  = surface pressure on the shaft.

Built-in principle of an ETP-connection.

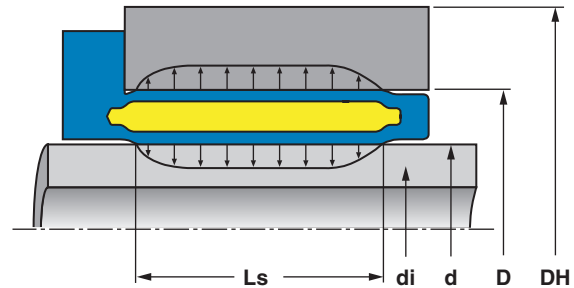

When the loads are in form of alternating or pulsating torque it is recommended to reduce the transmittable torque rating,  $T$ . For further information see technical specification sheet for corresponding product.

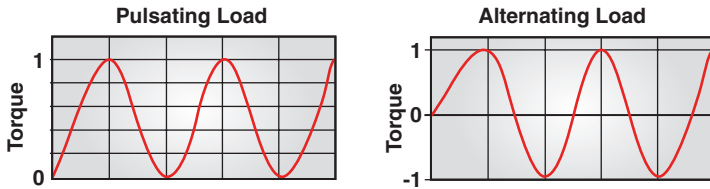

## Dimensioning of Hubs and Hollow Shafts

Because of the even and reasonable surface pressure and the compact built-in dimensions of the ETP connections, a thin material for the hub and shaft can be used. Also aluminium is possible.

For hubs and hollow shafts in steel, the yield point of those materials decides the minimum thickness of the material. For cast iron and aluminium, the module of elasticity is decisive.

The requisite thickness can be selected from the below table or more accurately in the diagram.

NOTE: This information is not valid for ETP-HYLOC or ETP-OCTOPUS.

$ReL$  = Yield point for the material.

$E$  = Module of elasticity.

$D_H$  = The minimum outer diameter of the hub.

$d_i$  = The maximum inner diameter of the hollow shaft.

If  $D_H/D < 1.4$  for the hub or if  $d_i/d > 0.6$  for the hollow shaft, contact us for advice.

For all materials there will be an elastic expansion/compression of the hub/hollow shaft.

The expansion/compression will not be uniform of the hub/hollow shaft if the material is unsymmetrical.

For accurate calculation contact us.

### Hub

Material	$D_H/D$
Steel incl. stainless, $ReL > 300 \text{ N/mm}^2$	1.4
Steel incl. stainless, $ReL > 220 \text{ N/mm}^2$	1.5
Cast iron, $E=120 \text{ kN/mm}^2$	2.0
Aluminium, $E=70 \text{ kN/mm}^2$	2.5

### Hollow Shaft

Material	$d_i/d$
Steel incl. stainless, $ReL > 300 \text{ N/mm}^2$	0.6
Steel incl. stainless, $ReL > 240 \text{ N/mm}^2$	0.5
Cast iron, $E=120 \text{ kN/mm}^2$	0.3
Aluminium, $E=70 \text{ kN/mm}^2$	0.2

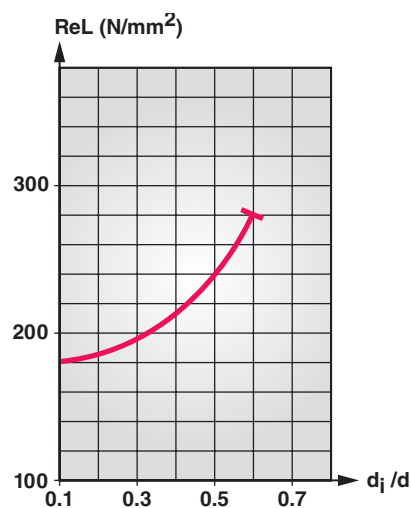

## Coefficient of Friction ( $\mu$ )

### Recommended Surface Finish, Shaft/Hub

Ra max 3.0 ( $\mu\text{m}$ )  
Ra min 1.0 ( $\mu\text{m}$ )

The coefficient of friction depends on a number of factors. The most important are:

### SURFACE FINISH

The surface must not be too smooth. If it is, the influence of impurities can be significant. A good turning operation is often better than grinding.

### CLEANLINESS

It is very important that the surfaces are well cleaned. Grease on the surfaces will drastically reduce the coefficient of friction. A thin oil will, however, only reduce the coefficient of friction by about 0.03  $\mu$ .

## Keyways

If there is a keyway in the shaft or hub, we recommend it to be filled in with, for example, some two component hardening medium (not needed for ETP-MINI). The medium should then be ground to the diameter of the shaft/hub. This prevents deformation and dismantling problems of the double-walled sleeve.

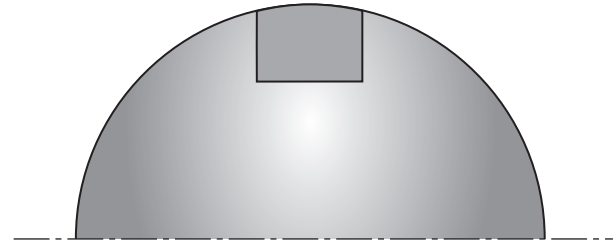

## Number of Mountings

One of the qualities with the ETP connections are their ability to be mounted quickly and repeatedly with maintained performance and precision.

There is, however, a limit when the screw/screws will be worn and have to be changed. If the threads are cleaned and regularly lubricated, the guide values in the table can be used.

The values indicate when the screw needs to be changed allowing the ETP connection to last longer.

For the R types it is very important that the screws are well lubricated when tightening, both for proper function and full lifetime capabilities. When used in food processing applications or similar we recommend the lubricant Molykote P-1900. For other applications Molykote G-n plus can be used.

ETP-HYLOC is not recommended for more than 2,000 mountings.

ETP Connection	Number of mountings
ETP-EXPRESS 15-35	2,000
ETP-EXPRESS 38-60	1,000
ETP-EXPRESS 70-100	500
ETP-EXPRESS R 15-35	800
ETP-EXPRESS R 38-60	400
ETP-EXPRESS R 70-80	200
ETP-TECHNO 15-45	5,000
ETP-TECHNO 50-75	3,000
ETP-TECHNO 80-130	500
ETP-POWER 15-30	500
ETP-POWER 32-40	200
ETP-CLASSIC	100
ETP-CLASSIC R	50
ETP-MINI	100
ETP-MINI R	50
ETP-HYLOC	2,000

## Surface Pressure

If the surface pressure is too low, a metallic contact between the surfaces will not be created because of oxide layers. If the surface pressure is too high, plastic deformation can occur and the friction will decrease dramatically. The hydraulic ETP principle gives a surface pressure within the right range, which is also even around and along the entire contact area.

The surface pressure from the ETP connections (not ETP-HYLOC) at the recommended tightening torque is approximately 80 N/mm<sup>2</sup>.

## Runout and Balance

The hydraulic ETP principle assures a good runout and balance. All products are balanced by design. For guide values see the table.

To these values the runout/unbalance for shaft and hub in the actual case has to be added in order to get the final value when mounted.

Balancing can be done on request.

ETP-EXPRESS and ETP-TECHNO upon request can be dynamically balanced to G 2.5, at a requested rpm.

Material	ETP-EXPRESS incl. type R and C	ETP-TECHNO	ETP-POWER	ETP-CLASSIC incl. type R	ETP-MINI incl. type R	ETP-HYLOC
Runout (mm)*	≤ 0.02	≤ 0.006	≤ 0.03	0.03 – 0.06	≤ 0.02	≤ 0.02
Unbalance (gmm/kg)	75	50	75	100	100	75**

\* Values are also valid after repeated mountings.

\*\* For size ≤ 100 mm, with radial mounted steel plugs, the unbalance is larger.

## Temperature

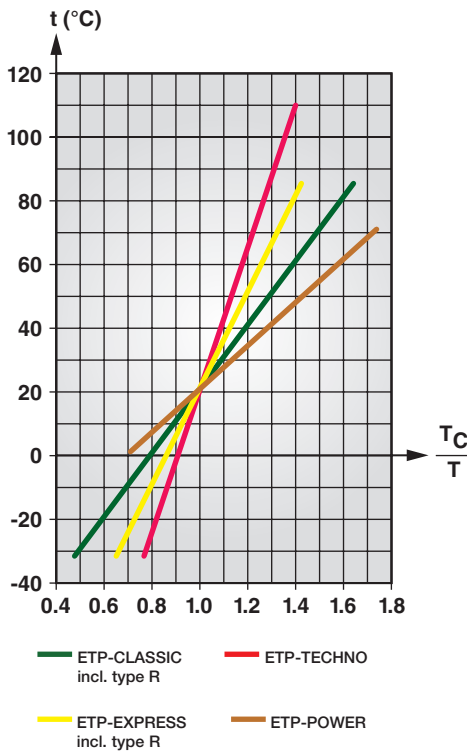

The pressure medium in hydraulic ETP connections and the double-walled steel sleeve have different volume expansion coefficients. This means that when the temperature rises, the pressure in the connection increases and a higher torque can be transmitted. The opposite is valid at decreasing temperature.

Also the seals built into the connections decides the upper and lower operating temperatures.

The following has to be taken into consideration when the operating temperature differs from the mounting temperature:

- Max. and min. temperature for continuous operation, see table. ETP-MINI and ETP-HYLOC can withstand wider upper and lower limits.
- The decrease in torque due to lower operating temperatures, see diagram. ETP-MINI and ETP-HYLOC are not affected.

T = transmittable torque.

T<sub>C</sub> = transmittable torque at operating temperature.

ETP Connection	Min. Temp. °C	Max. Temp. °C
ETP-EXPRESS incl. type R and C	-30	+85
ETP-TECHNO	-30	+110
ETP-CLASSIC incl. type R	-30	+85
ETP-POWER	0	+70

## Radial Loads and Bending Torque

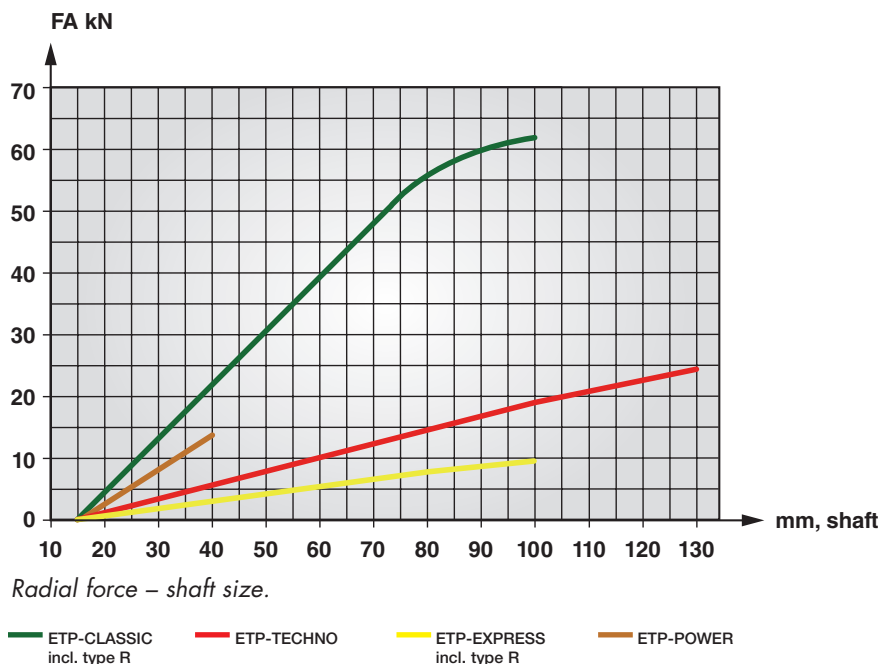

Radial force – shaft size.

### Examples of Radial Load

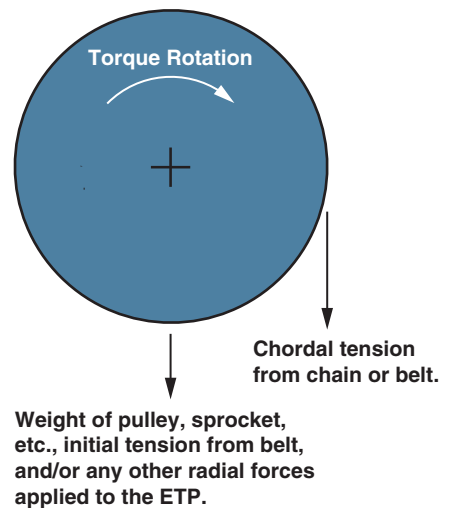

	ETP-EXPRESS incl. type R and C	ETP-TECHNO	ETP-POWER	ETP-CLASSIC incl. type R and C	ETP-MINI incl. type R	ETP-HYLOC
Bending torque as % of transmittable torque, T.	5	10	10	15	30	15

## Torque and Speed

Due to centrifugal force, the transmittable torque will be reduced with increasing speed (rpm). The diagram gives examples for ETP-TECHNO 50 with a steel hub. A reduced tolerance between the contact surfaces gives a higher surface pressure at the same tightening torque, and thus higher transmittable torque at high speeds. A thicker hub is more effected by the centrifugal force and the torque will reduce faster at increasing speed. The example is not directly applicable for other sizes or types of ETP connections. Contact us for assistance with calculations at high speeds.

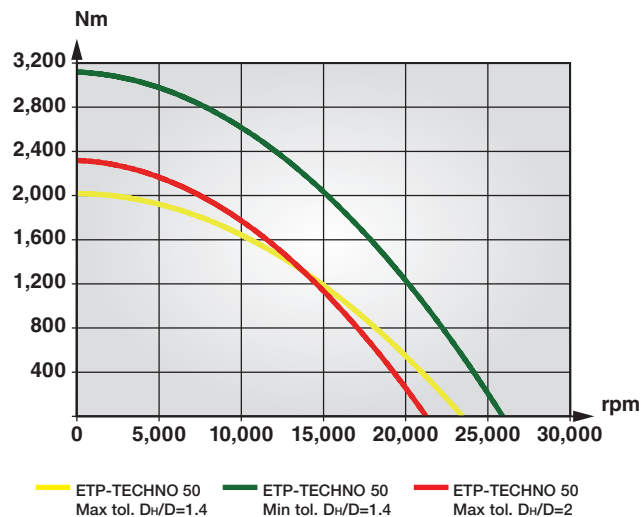

## Axial Force

If an axial force ( $F_1$ ) and a torque ( $T_1$ ) are to be transmitted at the same time, the following formula is valid.

$$\left(\frac{F_1}{F_A}\right)^2 + \left(\frac{T_1}{T}\right)^2 \leq 1$$

this means that the value should be inside the quarter circle in the diagram.

FA and T are the rated values for axial force and torque for the different ETP products.

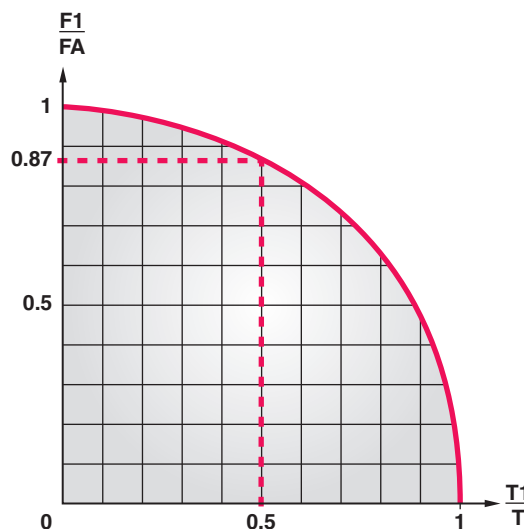

## Design Tips

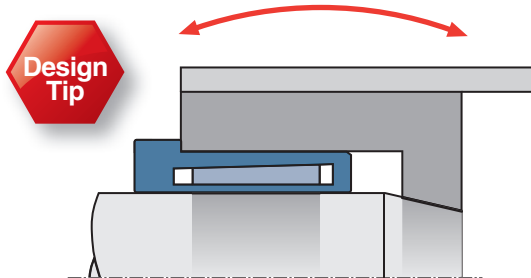

Most friction joints have limited capacity to transmit radial forces and bending torque. High levels of these loads can affect the function of the ETP connection. The values acc. to the diagram and table based on tests can serve as guide lines. ETP-MINI and ETP-HYLOC can transmit higher radial forces than the other connections.

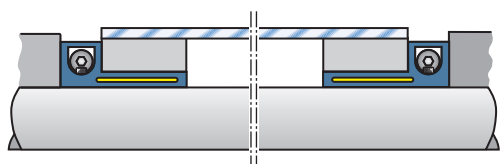

ETP-TECHNO gives advantages when used to fasten printing cylinders in light materials, for example aluminium. The cylinder can be changed 1,000s of times, using the same ETP-TECHNO, with maintained good concentricity and repeatability. The radial access to the screw facilitates the handling and saves space.

At varying temperature and with a hub made from aluminium ETP-connections can be used. Because of the even surface pressure and the lack of slotted sleeves, ETP-connections can function as a sealing element up to a pressure difference,  $p_1 - p_2$ , of 50 bar.

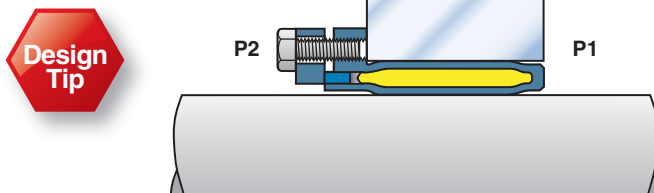

When manufacturing precision gears, they can be fastened with ETP- EXPRESS. If the gear is fixed in its position with an axial screw or pin before the last grinding operation, a repeatability within  $2 \mu\text{m}$  will be achieved.



# PRECISE. RELIABLE. ROBUST. AVAILABLE.



## CD® Couplings

High-performance couplings that outperform and outlast bellows and steel disc designs. The unique design of the composite disc enables the CD Couplings to withstand punishing applications and deliver high precision performance. Fully Customizable.



## Keyless Shaft Locking Devices

ETP® keyless connections and Posi-Lok® keyless bushings provide quick, easy and accurate assembly of mounted shaft components. Both inch and metric bore sizes are available from stock.

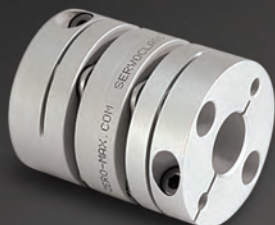

## ServoClass® Couplings

Designed for demanding servomotor applications. Zero backlash, high torsional stiffness, high speed design. Features flexible metal discs for high misalignment capacity and keyless clamp-type mounting hubs.

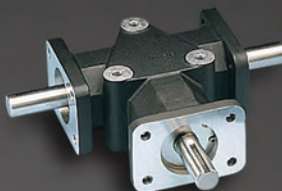

## Crown Gear Drives

Available in 5-sizes, 3 configurations, and with 1:1 and 2:1 ratios. High quality AGMA class 10 spiral bevel gears. Stainless steel shafts and either black anodized or IP65-Rated nickel-plated aluminum housing.



## Schmidt Offset Couplings

Designed to handle high amounts (up to 17") of parallel shaft offset with constant angular velocity. Standard models with torque capacities up to 459,000 in-lbs and extensive custom capabilities.



## Adjustable Speed Drives

Easy to install and maintenance free. Zero-Max® Drives offer infinitely variable speeds from 0 rpm to 1/4 of input rpm. 5 models with torque ranges from 12 in-lbs to 200 in-lbs.

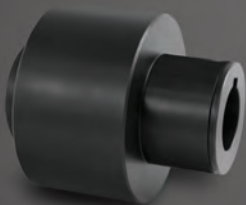

## Overload Safety Couplings

Torque Tender® Couplings provide reliable overload protection in any mechanical power transmission system. Full selection of styles and sizes with set-point torque ranges from 3 to 3,000 in-lbs.



## Roh'Lix® Linear Actuators

Simple conversion of rotary motion into precise linear motion. Available in five models and multiple configurations. Roh'Lix actuators have thrust ratings from 5 to 200 lbs. All models feature built-in overload protection.



## Control-Flex Couplings

Zero backlash couplings designed for encoder and instrumentation type applications. Features high misalignment capacity, constant velocity, and an electrically isolated hub design.

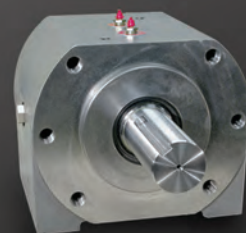

## OHLA® Overhung Load Adaptors

Designed to protect hydraulic motors and pumps from radial/axial loads and to provide additional seal protection. 11 models available for mounts from SAE A to SAE F. Fully customizable.

Warranty. Zero-Max, Inc. the manufacturer, warrants that for a period of 12 months from date of shipment it will repair, or at its option, replace any new apparatus which proves defective in material or workmanship, or which does not conform to applicable drawings and specifications approved by the manufacturer. All repairs and replacements shall be F.O.B. factory. All claims must be made in writing to the manufacturer. ● In no event and under no circumstances shall manufacturer be liable for (a) damages in shipment; (b) failures or damages due to misuse, abuse, improper installation or abnormal conditions of temperature, dirt, water or corrosives; (c) failures due to operation, intentional or otherwise, above rated capacities, and (d) non-authorized expenses for removal, inspection, transportation, repair or rework. Nor shall manufacturer ever be liable for consequential and incidental damages, or in any amount greater than the purchase price of the apparatus. ● Zero Max, Inc. reserves the right to discontinue models or to change specifications at any time without notice. No discontinuance or change shall create any liability on the part of Zero-Max, Inc. in respect to its products in the hands of customers or products on order not incorporating such changes even though delivered after any such change. ● This warranty is in LIEU OF ALL OTHER WARRANTIES, EXPRESS OR IMPLIED, INCLUDING (BUT NOT LIMITED TO) ANY IMPLIED WARRANTIES OF MERCHANTABILITY OR FITNESS FOR A PARTICULAR PURPOSE. THE TERMS OF THIS WARRANTY CONSTITUTE ALL BUYER'S OR USER'S SOLE AND EXCLUSIVE REMEDY, AND ARE IN LIEU OF ANY RIGHT TO RECOVER FOR NEGLIGENCE, BREACH OF WARRANTY, STRICT TORT LIABILITY OR UPON ANY OTHER THEORY. Any legal proceedings arising out of the sale or use of this apparatus must be commenced within 18 months of the date of purchase. ● CAUTION: Rotating equipment must be guarded. Also refer to OSHA specifications and recommendations. ● Zero-Max®, CD®, ETP®, ServoClass®, Torq-Tender®, Posi-Lok®, Roh'Lix®, and OHLA® are registered trademarks of Zero-Max, Inc. In U.S.A.

©Zero-Max, Inc., All Rights Reserved  
Printed in U.S.A., Rev1.055

# ////// ZERO-MAX®

13200 Sixth Avenue North, Plymouth, Minnesota 55441-5509  
Phone 800.533.1731 763.546.4300 FAX 763.546.8260

zero-max.com