

1.

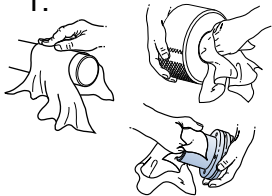

2.

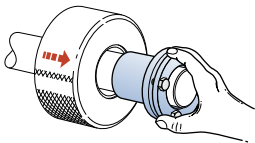

UK: Tighten the screws half a turn at a time to the prescribed torque

DE: Schrauben der Reihenfolge nach je eine halbe Umdrehung bis auf das angegeben Anzugsmoment anziehen.

FR: Serrer progressivement les vis d'un demi-tour à la fois jusqu'au couple de serrage recommandé. Procéder par serrage successif en évitant tout serrage en croix.

ES: Los tornillos se apretarán sucesivamente media vuelta cada vez, por orden correlativo, alrededor de la brida hasta el par de apriete dado.

IT: Serrate le viti per non più di mezzo giro alla volta, l'una dopo l'altra, sino al raggiungimento della coppia di serraggio indicata a catalogo.

ETP-CLASSIC R	T (Nm)
15 - 40	4,5
45 - 50	7,8

3.1

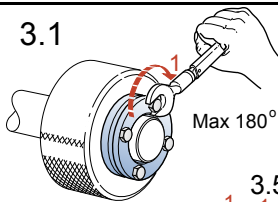

Max 180°

3.2

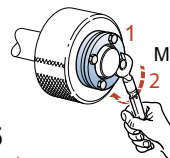

Max 180°

3.5

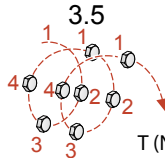

3.4

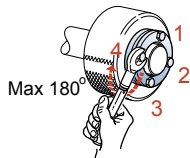

Max 180°

T (Nm)

3.3

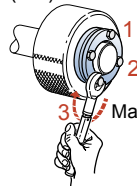

Max 180°

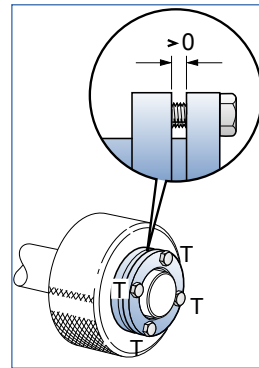

UK: Loosen the screws, half a turn at a time, in consecutive order, until ETP-CLASSIC R is loose.

DE: Schrauben in umgekehrter Reihenfolge je eine halbe Umdrehung lösen bis ETP-CLASSIC R sich drehen lässt.
FR: Desserrer les vis d'un demi-tour à la fois jusqu'au déblocage du ETP-CLASSIC R.

ES: El desmontaje se efectuará en orden inverso es decir los tornillos se aflojarán sucesivamente, media vuelta cada vez por orden correlativo, alrededor de la brida.
IT: ETP-CLASSIC R può essere rimossa semplicemente allentando le viti, mezzo giro per volta, sino al completo smontaggio.

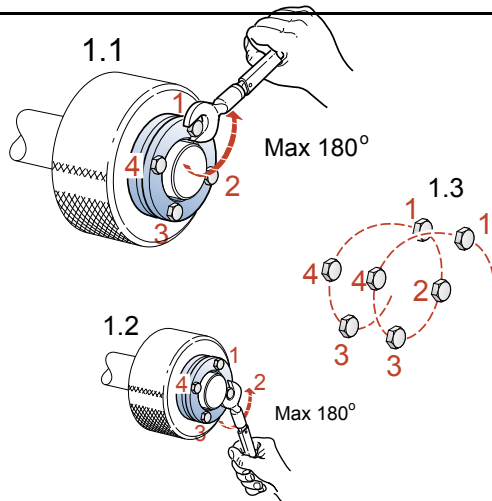

2.

