

MOTION CONTROL PRODUCTS

Mounting and Lubrication Instructions for Schmidt Offset Couplings

For Coupling Models: **L350C & L355C**

The Schmidt Offset Coupling will function properly if these mounting, maintenance and lubrication instructions are followed. Failure to observe these instructions may result in reduced coupling life.

Mounting Instructions

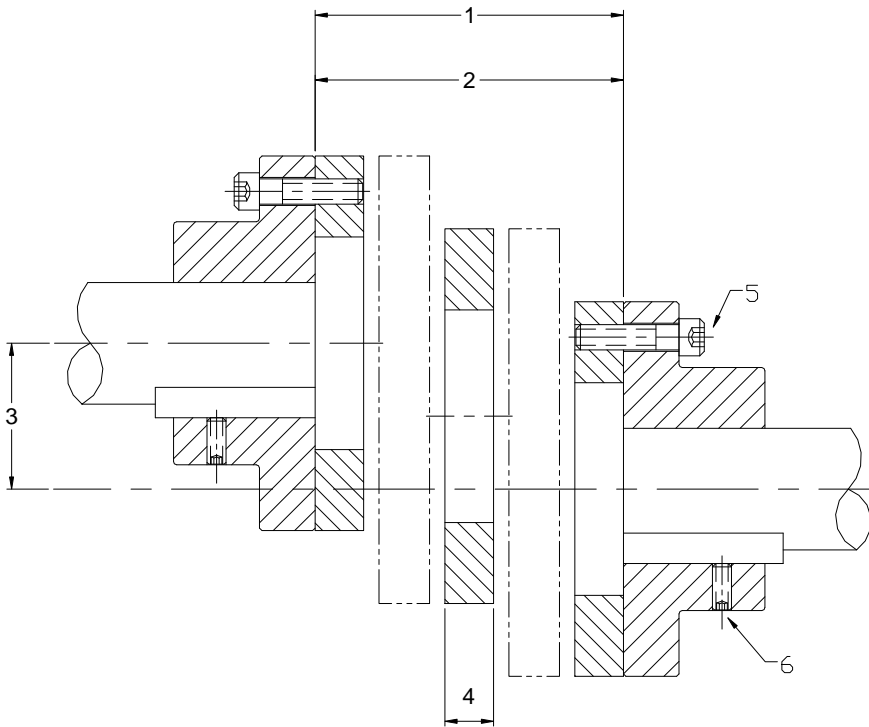

It is important that the following assembly dimensions and tolerances are maintained before and during coupling operation.

Lubrication Instructions

The Schmidt Offset Coupling should be lubricated after the first 200 hours of operation, and again as specified by the lubrication schedule below.

RPM	Under 500	500 to 1000	Over 1000
Lube Cycle	Every 1000 Hours	Every 500 Hours	Every 200 Hours

Note: Always make certain that the lubrication fittings are clean before adding lubricant to prevent the introduction of foreign matter into the bearings. Use standard Alemite flush-type fitting Z-737. Recommended Lubricant: Darina No. 2 (EP) Oil based grease

Position shafts and hubs according to the following values:

1. Hub faces to be parallel within:----->
 Speeds above 1000 rpm should be .015 inch or less.

Minimizing angular misalignment will allow the coupling bearings to achieve their maximum lifetime.

2. Distance between the hub faces:----->

3. Minimum shaft displacement not less than:----->

Maximum shaft displacement not to exceed:----->

The Schmidt Offset Coupling cannot operate properly outside these limits.

4. Mount coupling between hubs. After installation of the coupling, check that the center disc is free to move laterally a small amount (approximately .015"-.025").

5. Tighten hub bolts to the end discs of the coupling.

6. Tighten setscrews in hub. If shock loads are expected, use two set screws per hub.

Spare Parts for Schmidt Offset Couplings

Item Description	Item Number	L350C	L355C
Quantity Required Per Coupling			
Spacer	S952700	12	16
Thrust Washer	S952800	12	16
Flat Head Screw	S458500	12	16
Tinnerman Washer	S952300	12	16
Needle Bearing	S501100	12	16
Link Assembly	S701150	6	8
Long Shaft	S853600	3	4
Short Shaft	S853700	6	8

Rebuild Kits for Schmidt Offset Couplings

Standard rebuild kits are available for Schmidt Offset Couplings. Rebuild kits consist of links with needle bearings, spacers, thrust washers, Tinnerman washers, and flat head screws.

Coupling Model	Repair Kit p/n
L350C	S040060
L355C	S040160

